

Status: Inactive

110552

Copy No. 4

NACA RM No. 51711

McDonnell

CLASSIFICATION CANCELLED

RESTRICTED

P 25/2



RESEARCH MEMORANDUM

for the

Air Materiel Command, Army Air Forces

SUPPLEMENTARY FREE-SPINNING-TUNNEL TESTS OF A $\frac{1}{16}$ -SCALE
MODEL OF THE MCDONNELL XP-85 AIRPLANE EQUIPPED WITH A
CONVENTIONAL-TAIL ARRANGEMENT

By

Walter J. Klinar

Langley Memorial Aeronautical Laboratory
Langley Field, Va.

CLASSIFIED

CLASSIFIED DOCUMENT

This document contains classified information affecting the National Defense of the United States within the meaning of the Espionage Act, USC 50:31 and 32. Its transmission or the revelation of its contents in any manner to an unauthorized person is prohibited by law. Information so classified may be imparted only to persons in the military and naval services of the United States, appropriate civilian officers and employees of the Federal Government who have a legitimate interest therein, and to United States citizens of known loyalty and discretion who of necessity must be informed thereof.

TECHNICAL EDITING WAIVED

CONTAINS PROPRIETARY INFORMATION

NATIONAL ADVISORY COMMITTEE FOR AERONAUTICS

WASHINGTON

OCT 13 1947

FILE COPY

To be returned to
the files of the National
Advisory Committee
for Aeronautics
Washington, D. C.

CLASSIFICATION CANCELLED

RESTRICTED

NATIONAL ADVISORY COMMITTEE FOR AERONAUTICS

RESEARCH MEMORANDUM

for the

Air Materiel Command, Army Air Forces

SUPPLEMENTARY FREE-SPINNING-TUNNEL TESTS OF A $\frac{1}{16}$ -SCALE
MODEL OF THE MCDONNELL XP-85 AIRPLANE EQUIPPED WITH A
CONVENTIONAL-TAIL ARRANGEMENT

By Walter J. Klinar

SUMMARY

Spin tests have been conducted in the Langley free-spinning tunnel on a $\frac{1}{16}$ -scale model of the McDonnell XP-85 airplane with the normal X-tail replaced with a short-coupled conventional-tail arrangement. The effect of the conventional-tail arrangement and the effects of various modifications upon the spin and recovery characteristics of the model were determined.

The results of the tests indicated that installation of the conventional-tail arrangement will not provide satisfactory recoveries from spins of the airplane. Satisfactory recoveries will be obtainable, however, either by installing in addition a very large ventral fin (17.94 sq ft, full-scale) below the tail or by decreasing the width of the fuselage and making it flat sided rearward of the wing trailing edge.

INTRODUCTION

The results of the spin tests of a $\frac{1}{16}$ -scale model of the McDonnell XP-85 airplane, reported in reference 1, indicated that unsatisfactory spin-recovery characteristics would be obtained with the originally proposed X-tail installed on the airplane. Accordingly, an alternate conventional-tail arrangement having somewhat better normal-flight stability characteristics than the X-tail (reference 2) was proposed in an attempt to improve satisfactorily the spin-recovery characteristics. Results of the additional spin tests with the conventional tail installed

on the model are reported herein. Several alternate modifications, including the flattening and narrowing of the sides of the fuselage rearward of the wing trailing edge, were tested on the model in an attempt to improve the recovery characteristics of the model.

SYMBOLS

b	wing span, feet
S	wing area, square feet
\bar{c}	mean aerodynamic chord, feet
x/\bar{c}	ratio of distance of center of gravity rearward of leading edge of mean aerodynamic chord to mean aerodynamic chord
z/\bar{c}	ratio of distance between center of gravity and fuselage center line to mean aerodynamic chord (positive when center of gravity is below fuselage center line)
m	mass of airplane, slugs
I_X, I_Y, I_Z	moments of inertia about X-, Y-, and Z-body axes, respectively, slug-feet ²
$\frac{I_X - I_Y}{mb^2}$	inertia yawing-moment parameter
$\frac{I_Y - I_Z}{mb^2}$	inertia rolling-moment parameter
$\frac{I_Z - I_X}{mb^2}$	inertia pitching-moment parameter
ρ	air density, slugs per cubic foot
μ	relative density of airplane $\left(\frac{m}{\rho S b} \right)$
α	angle between fuselage center line and vertical (approximately equal to absolute value of angle of attack at plane of symmetry), degrees
ϕ	angle between span axis and horizontal, degrees

V	full-scale rate of descent, feet per second
Ω	full-scale angular velocity about spin axis, revolutions per second
σ	helix angle, angle between flight path and vertical, degrees (For tests of this model, average absolute value of helix angle was approximately 1° .)
β	approximate angle of sideslip at center of gravity, degrees (Sideslip is inward when inner wing is down by an amount greater than the helix angle.)
URVC	unshielded rudder volume coefficient (See reference 3.)
TDR	tail-damping ratio (See reference 3.)
TDPF	tail-damping power factor (See reference 3.)

APPARATUS AND METHODS

Model

The $\frac{1}{16}$ -scale model used for the tests was the same as that used for the tests reported in reference 1 except that the X-tail was replaced by a conventional-tail arrangement. A three-view drawing of the model with the conventional-tail installation is shown in figure 1. Airplane dimensional characteristics as represented by the model as tested in the free-spinning tunnel are given in table I.

A photograph of the model in the clean condition is shown in figure 2. Figure 3 is a drawing of the vertical tail, and figure 4 shows alternate horizontal tails tested. Mr. D. S. Lewis of the McDonnell Aircraft Corporation had indicated that the larger horizontal tail is required for stability. The smaller horizontal tail is so dimensioned that it will fit into the B-36 bomb bay without folding. Sketches of the various modifications are shown in figures 5 to 8.

As before, the model was ballasted to obtain dynamic similarity to the airplane at an altitude of 15,000 feet ($\rho = 0.001496$ slug/cu ft). The mass data used in ballasting the model for the tests reported in reference 1 were also used for the current tests since it appears that substituting the conventional tail for the X-tail will alter the mass characteristics of the airplane very slightly.

Wind Tunnel and Testing Technique

The tests were performed in the Langley 20-foot free-spinning tunnel, the operation of which, in general, is similar to that of the Langley 15-foot tunnel described in reference 4 except that the model-launching technique has been changed. With the controls set in the desired positions, the model is launched by hand with rotation into the vertically rising air stream. After a number of turns in the established spin, recovery attempt is made by moving one or more controls by means of the remote-control mechanism. After recovery, the model dives into a safety net. A photograph of the model during a spin is shown in figure 9.

The testing technique applied and method of determining spin data were essentially the same as for reference 1. The control configuration and manipulation used for the "criterion spin" for these tests were as follows: elevator set at either full up or at two-thirds of its full-up deflection (depending on which gave the more conservative results; if it was not obvious which elevator setting would give the slower recoveries, both settings were tested), ailerons set at one-third of full deflection in the direction conducive to slower recoveries (against the spin for the unmodified model, and with the spin for some of the modifications tested), and rudder placed at full with the spin and reversed to only two-thirds of its full deflection against the spin for recovery. For some of the current tests, recovery was attempted by simultaneously moving the elevator from full up to full down in conjunction with rudder reversal. As is explained in reference 1, recovery characteristics may be considered satisfactory if recovery attempted from the criterion spin requires $2\frac{1}{4}$ turns or less.

PRECISION

The spin results presented herein are believed to be the true values given by the model within the following limits:

α , degree	± 1
ϕ , degree	± 1
V, percent	± 5
Ω , percent	± 2

Turns for recovery	}	$\pm\frac{1}{4}$ turn when obtained from motion-picture records
		$\pm\frac{1}{2}$ turn when obtained by visual estimate

The preceding limits may have been exceeded for certain spins in which it was difficult to control the model in the tunnel because of the high rate of descent or because of the wandering or oscillatory nature of the spin.

Comparison between model and airplane spin results (references 4 and 5) indicates that spin-tunnel results are not always in complete agreement with airplane spin results. In general, the models spun somewhat steeper at a somewhat higher rate of descent and at from 5° to 10° more outward sideslip than did the corresponding airplanes. The comparison made in reference 5 for 20 airplanes showed that 80 percent of the models predicted satisfactorily the number of turns required for recovery from the spin for the corresponding airplanes and that 10 percent overestimated and 10 percent underestimated the corresponding turns for recovery.

Because of the impracticability of ballasting the model exactly and because of inadvertent damage to the model during the tests, the measured weight and mass distribution of the model varied from the true scaled-down values within the following limits:

Weight, percent	0 to 1 high
Center-of-gravity location, percent \bar{c}	no variation
Moments of Inertia {	I_x , percent 3 high to 7 high
	I_y , percent 3 high to 5 high
	I_z , percent 3 low to 2 high

The accuracy of measuring the weight and mass distribution of the model are believed to be within the following limits:

Weight, percent	± 1
Center-of-gravity location, percent \bar{c}	± 1
Moments of inertia, percent	± 5

Control settings were made with an accuracy of $\pm 1^\circ$

TEST CONDITIONS

Tests were performed for the model conditions listed on table II. The major part of the tests was conducted with the larger horizontal tail installed on the model (tail 2 on fig. 4). All tests were conducted with the model in the clean condition. The clean condition is defined as follows: flaps retracted, landing hook retracted, and cockpit closed.

The mass characteristics and the mass parameters for the normal loading on the airplane and for the actual loadings tested on the model are listed on table III. The mass distribution parameters for

these loadings are plotted on figure 10. As discussed in reference 6, figure 10 can be used as an aid in predicting the relative effectiveness of the controls during recovery from spin. It will be noted on table III that when the horizontal tail was raised to the top of the fin, the moments of inertia increased and the mass distribution parameters changed somewhat. No attempt was made to reballast the model to the original normal loading for these tests as it was felt that a somewhat similar change in moments of inertia would necessarily occur on the airplane if the horizontal tail were shifted to the top of the fin. In addition, the critical mass factors that affect the spin were altered so slightly by this modification that similar results would probably have been obtained had the model been reballasted to its normal loading.

The maximum control deflections used in the tests were:

Rudder, degrees	20 right, 20 left
Elevator, degrees	40 up, 20 down
Ailerons, degrees	20 up, 20 down

The intermediate control deflections used for the spin tests were:

Rudder two-thirds deflected, degrees	14
Elevator two-thirds full up, degrees	27
Ailerons one-third deflected, degrees	7 up, 7 down

RESULTS AND DISCUSSION

The test results are presented in charts 1 to 7 and table IV. The model data are presented in terms of the full-scale values for the airplane at a test altitude of 15,000 feet. Due to some inherent asymmetry in the model, results of right and left spins differed somewhat and the results are generally presented for the spins in both directions. It is felt that for a truly symmetrical model, the actual turns for recovery would be an average of the results obtained to the right and to the left.

Unmodified Conventional Tail

Large horizontal tail.— The effect of control setting on the steady-spin and recovery characteristics of the conventional-tail model in the normal loading are presented on chart 1 for tests with the large horizontal tail installed on the model. For the normal-spin control configuration (rudder full with the spin, elevator full up, and ailerons neutral) recoveries from the right spins by full rudder reversal or by full simultaneous reversal of rudder and elevator were unsatisfactory, whereas for the spins to the left, satisfactory recoveries were obtained.

By averaging the number of turns required for recovery for the right and the left spins at this control setting, a number in excess of 2 turns (the maximum number of turns allowable for a satisfactory recovery) is obtained.

Setting the elevator down before reversing the rudder generally aided recovery except when the ailerons were full against the spin. Setting the ailerons with the spin (right aileron up and left aileron down in a right spin) was favorable and generally led to rapid recoveries, whereas setting the ailerons against the spin was adverse.

In order to evaluate the possible adverse effects on recovery of small deviations from the normal control configuration for spinning, tests were run at the control configuration previously referred to as the criterion spin (for these tests, ailerons were one-third against the spin, and elevator was either full up or two-thirds up). As is shown on chart 1, recoveries from the criterion spin in either direction were unsatisfactory even when both rudder and elevator were reversed fully and simultaneously. On the basis of these test results, the recovery characteristics of the model are considered unsatisfactory, and it appears that normal-control manipulation for recovery (full rapid rudder reversal, followed approximately 1/2 turn later by movement of the stick well forward of neutral) will not satisfactorily terminate a fully developed spin. Thus, compared to the results presented in reference 1, it is apparent that the conventional-tail installation offers little improvement over the X-tail arrangement.

Small horizontal tail.— The test results obtained with the small horizontal tail installed on the model are shown on chart 2. Only brief tests were run with this tail installed on the model inasmuch as the spin and recovery characteristics were similar to those obtained with the large horizontal-tail installation.

Modifications

A few modifications were made to the model in an attempt to improve the spin-recovery characteristics of the model. The modifications are tabulated on table IV and are classified as ineffective, marginal, or effective. The test results for the modifications tested are presented on charts 3 to 7.

The ventral-fin modifications 1 to 3 are classified as ineffective because they did not enable the model to recover satisfactorily from the criterion spin. The test results for these modifications are shown on charts 3 and 4 and sketches of the modifications are shown in figures 5 and 6.

When the horizontal tail was moved to the top of the fin (fig. 7) the model would not remain in the spin indefinitely at the criterion-spin control setting but would eventually recovery without use of

the controls. As is shown on chart 5, however, for the spin tests to the right the model took a large number of turns in a flat attitude before the rotation imparted to the model on launching ceased and the model dived out of the spin. When the model was spinning at this flat attitude, unsatisfactory recoveries were obtained, even when rudder reversal was accompanied by full reversal of the elevator. It thus appears that flat spins and unsatisfactory recoveries might possibly be obtained on the airplane modified in this manner and, accordingly, this modification is considered marginal.

The two modifications classified as effective on table IV definitely led to satisfactory recovery characteristics. With modification 5 installed on the model (large ventral fin shown on figure 6, approximate full-scale area 17.94 sq ft), the model did not spin at the criterion-spin control setting and the original launching rotation was damped out rapidly. This is the same size ventral fin that appeared necessary to satisfactorily improve the recovery characteristics of the X-tail model (reference 1). The test results for the model with this ventral fin installed are shown on chart 6. The other effective modification is shown in figure 8 for the model as tested in a right spin. For these tests to the right, the left rear side of the fuselage was cut away (side exposed to the air stream) as indicated on figure 8 and the right side (unexposed side) was retained. For the tests to the left, the left side of the fuselage was replaced and the right side was removed. The model test results, presented on chart 7, show that the model recovered satisfactorily with this fuselage modification, indicating that if the airplane were constructed with a sufficiently flat and narrow fuselage section near the tail, the conventional-tail design would probably lead to satisfactory recoveries.

As is shown on table IV, although no increase in tail-damping-power factor was effected by slicing off the sides of the fuselage (modification 6) the spin-recovery characteristics of the model were improved considerably, but when the horizontal tail was raised to the top of the fin, causing a large increase in tail-damping power factor, the spin-recovery characteristics of the model were still not considered satisfactory. It appears that flattening and narrowing the side of the fuselage near the tail probably caused an increase in damping by enabling an unrestricted flow of air to reach the portion of the vertical tail below the horizontal tail thereby increasing the effectiveness of the rudder below the horizontal tail, and, at the same time, increasing the air "trapping" effect of the horizontal tail. In addition, the flat-sided fuselage probably provided more rotational damping than did the rounded fuselage. The fact that the spin-recovery characteristics of the model were still not quite satisfactory even when the horizontal tail was raised to the top of the fin indicates that for this short-coupled design, a certain portion of the vertical tail was probably shielded by the wake of the wing during the spin, thus being ineffective in damping out the spin rotation.

CONCLUSIONS

Based on results of tests of a $\frac{1}{16}$ -scale model of the XP-85 airplane with a conventional tail, the following conclusions regarding the spin and recovery characteristics of the airplane at a test altitude of 15,000 feet have been made:

1. The fully developed spin will probably not be satisfactorily terminated by normal-control manipulation for recovery. Similar spin and recovery characteristics will be obtained with either the large or the small horizontal tail surfaces installed on the airplane.
2. Installing a large ventral fin (17.94 sq ft, full-scale) below the tail of the airplane will insure satisfactory recovery characteristics.
3. Decreasing the width of the fuselage and making it flat sided rearward of the wing trailing edge will probably enable the airplane to recover satisfactorily.

Langley Memorial Aeronautical Laboratory
National Advisory Committee for Aeronautics
Langley Field, Va.

Walter J. Klinar *su R*
Walter J. Klinar
Aeronautical Engineer

Approved: *Thomas A. Harris*

Thomas A. Harris
Chief of Stability Research Division

BUB

REFERENCES

1. Klinar, Walter J.: Free-Spinning and Tumbling Tests of a $\frac{1}{16}$ -Scale Model of the McDonnell XP-85 Airplane. NACA RM No. L7C10, Army Air Forces, 1947.
2. Paulson, John W. and Johnson, Joseph L.: Force Tests of a $\frac{1}{5}$ -Scale Model of the McDonnell XP-85 Airplane With Conventional Tail Assembly in the Langley Free-Flight Tunnel. NACA RM No. L7C26, Army Air Forces, 1947.
3. Neihouse, Anshal I., Lichtenstein, Jacob H., and Pepoon, Philip W.: Tail-Design Requirements for Satisfactory Spin Recovery. NACA TN No. 1045, 1946.
4. Zimmerman, C. H.: Preliminary Tests in the N.A.C.A. Free-Spinning Wind Tunnel. NACA Rep. No. 557, 1936.
5. Seidman, Oscar, and Neihouse, A. I.: Comparison of Free-Spinning Wind-Tunnel Results with Corresponding Full-Scale Spin Results. NACA MR, Dec. 7, 1938.
6. Neihouse, A. I.: A Mass-Distribution Criterion for Predicting the Effect of Control Manipulation on the Recovery From a Spin. NACA ARR, Aug. 1942.

TABLE I.- DIMENSIONAL CHARACTERISTICS OF THE XP-85 AIRPLANE EQUIPPED WITH A CONVENTIONAL TAIL AS REPRESENTED BY THE $\frac{1}{16}$ -SCALE MODEL

TESTED IN THE FREE-SPINNING TUNNEL

Length, over-all, ft	15.00
Wing:	
Span, ft	21.12
Area, sq ft	100
Section, root	NACA 65-010
Section, tip	NACA 65-010
Root chord incidence, deg	1
Tip chord incidence, deg	1
Aspect ratio	4.41
Sweepback at 25-percent chord, deg	34
Dihedral of wing, deg	-4
Mean aerodynamic chord, in.	61.91
Leading edge of \bar{c} aft leading-edge root chord, in.	41.36
Leading-edge flaps:	
Location of hinge line, percent chord	15
Span, percent of b/2	40.3
Ailerons:	
Total area, sq ft	3.00
Location of hinge line, percent chord	80
Span, percent of b/2	40.3
Horizontal tail no. 1:	
Total area, sq ft	13.22
Elevator area, aft hinge line, sq ft	4.62
Aspect ratio	2.22
Distance from normal center of gravity to elevator hinge line, ft	7.40
Airfoil section	66-009
Horizontal tail no. 2:	
Total area, sq ft	15.96
Elevator area, aft hinge line, sq ft	5.32
Aspect ratio	3.14
Distance from normal center of gravity to elevator hinge line, ft	7.40
Airfoil section	66-009
Vertical tail:	
Total area, sq ft	15.85
Rudder area, sq ft	6.39
Aspect ratio	2.49
Distance from normal center of gravity to rudder hinge line at horizontal-stabilizer-chord plane intersection, ft	7.25
Airfoil section	NACA 66-009
Tail-damping ratio	0.0535
Unshielded rudder-volume coefficient	0.0362
Tail-damping power factor	1937×10^{-6}

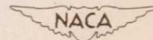

TABLE II.- CONDITIONS TESTED ON THE $\frac{1}{16}$ -SCALE MODEL OF THE MCDONNELL XP-85 AIRPLANE EQUIPPED WITH A CONVENTIONAL TAIL

Type of test	Loading	Horizontal tail installed	Modification	Method employed in recovery	Data presented
Right and left erect spins	Normal	Large	None	Rudder reversal and simultaneous rudder and elevator reversal	Chart 1
Do---	Normal	Small	None	Rudder reversal	Chart 2
Right erect spins	Normal	Large	Ventral fin - modification number 1	-----do-----	Chart 3
Do---	Normal	Large	Ventral fin - modification number 2	-----do-----	Chart 3
Right and left spins	Normal	Large	Ventral fin - modification number 3	-----do-----	Chart 4
Do---	Loading with horizontal tail atop fin	Large	Horizontal tail raised to top of fin - modification number 4	Rudder reversal and simultaneous rudder and elevator reversal	Chart 5
Do---	Normal	Large	Ventral fin - modification number 5	-----do-----	Chart 6
Do---	Normal	Large	Fuselage narrowed and flattened rearward of wing trailing edge - modification number 6	Rudder reversal	Chart 7

TABLE III.— MASS CHARACTERISTICS AND INERTIA PARAMETERS FOR THE XP-85 AIRPLANE AND FOR THE LOADINGS TESTED ON THE $\frac{1}{16}$ -SCALE MODEL

[Model values converted to corresponding full-scale values]

No.	Loading	Weight	Airplane relative density		Center of gravity		Moments of inertia			Inertia parameters		
			Sea level	15,000 ft	x/\bar{c}	z/\bar{c}	I_X (slug-ft ²)	I_Y (slug-ft ²)	I_Z (slug-ft ²)	$\frac{I_X - I_Y}{mb^2}$	$\frac{I_Y - I_Z}{mb^2}$	$\frac{I_Z - I_X}{mb^2}$
Airplane values												
1	Normal	4552	28.20	44.90	0.216	-0.013	740	1199	1509	-73.8×10^{-4}	-49.9×10^{-4}	123.7×10^{-4}
Model values												
1	Normal	4551	28.20	44.90	0.212	-0.027	748	1204	1433	-72×10^{-4}	-37×10^{-4}	110×10^{-4}
2	Loading with horizontal tail atop fin	4591	28.60	45.54	.212	-.043	888	1373	1551	-77×10^{-4}	-28×10^{-4}	105×10^{-4}

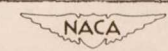

TABLE IV.- EFFECTIVENESS OF THE MODIFICATIONS TESTED ON THE $\frac{1}{16}$ -SCALE MODEL OF THE MCDONNELL XP-85 AIRPLANE

EQUIPPED WITH THE CONVENTIONAL-TAIL ARRANGEMENT

[Large horizontal tail installed on model]

Classification of model	Modification number	Figure number	Description of modification	Airfoil section and section thickness (full-scale)	Tail-damping power factor
Ineffective	1	5	Small ventral fin (approximate full-scale area equals 3.30 sq ft)	66-009	2300×10^{-6}
Ineffective	2	5	Triangular ventral fin (approximate full-scale area equals 7.30 sq ft)	Flat sheet 0.64 in. thick	2795
Ineffective	3	6	Rounded ventral fin (approximate full-scale area equals 12.42 sq ft)	66-009	3486
Marginal	4	7	Horizontal tail placed on top of fin and rudder made full length	-----	3899
Effective	5	6	Rounded ventral fin (approximate full-scale area equals 17.94 sq ft)	66-009	3790
Effective	6	8	Fuselage flattened and narrowed rearward of wing trailing edge	-----	1937

CHART 1.- SPIN AND RECOVERY CHARACTERISTICS OF THE $\frac{1}{16}$ -SCALE MODEL OF THE MCDONNELL XP-85 AIRPLANE EQUIPPED WITH A CONVENTIONAL TAIL; LARGE HORIZONTAL TAIL INSTALLED

[Normal loading (point 1 on table III and figure 10); recovery attempted by rapid full rudder reversal except as indicated (recovery attempted from, and steady-spin data presented for, rudder full-with spins); erect spins; direction of spin as indicated]

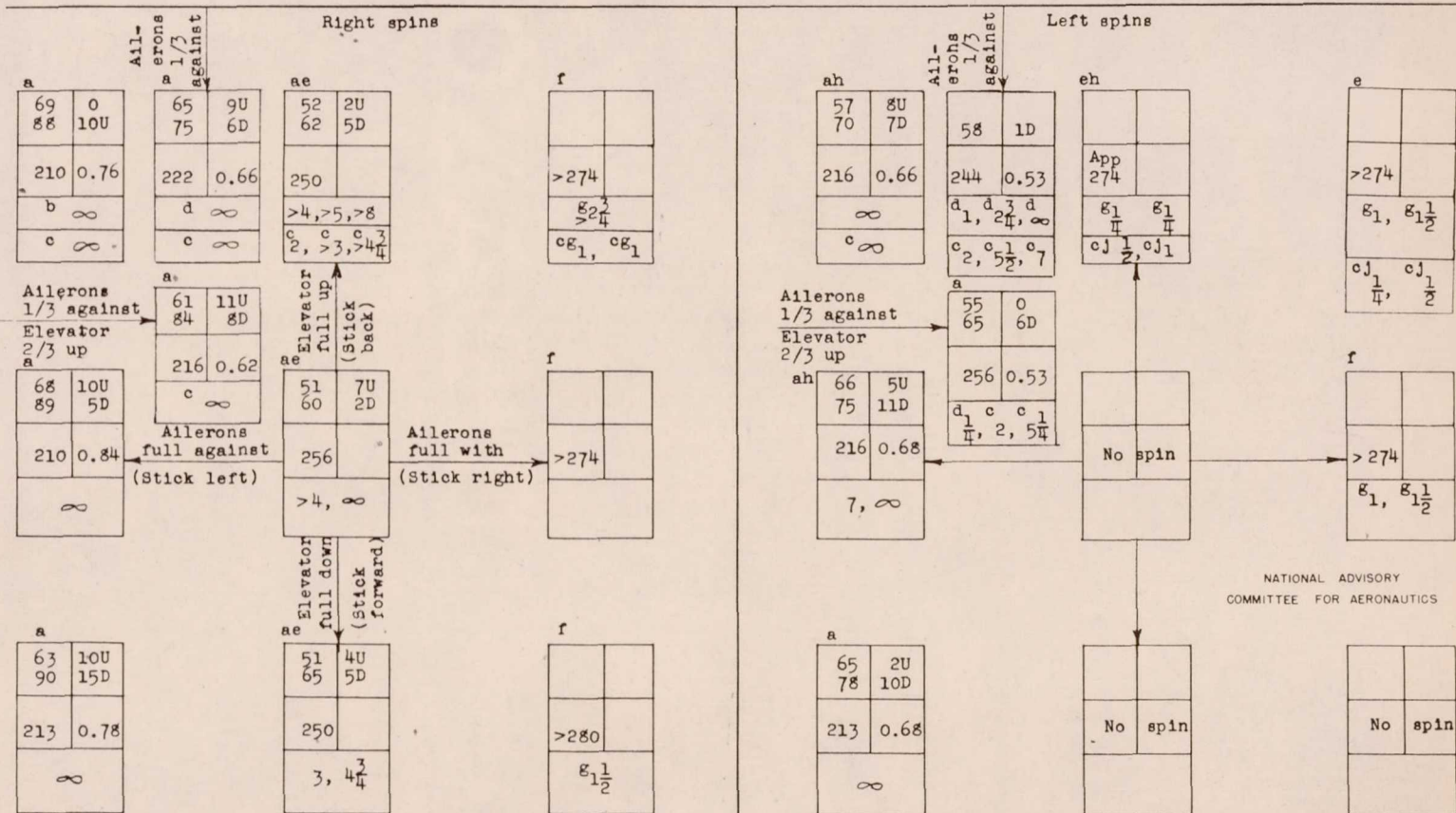

^aOscillatory, range or average values given.

^b ∞ means model required more than 10 turns for recovery.

^cRecovery attempted by simultaneous full reversal of rudder and elevator.

^dRecovery attempted by reversing the rudder from full with to only 2/3 against the spin.

^eWandering spin.

^fSteep spin with a whip to the turning motion.

^gRecovery attempted before model reached final steep attitude.

^hNo spin condition also obtainable.

^jVisual estimate.

Model values converted to corresponding full-scale values.
U inner wing up
D inner wing down

α (deg)	ϕ (deg)
V (fps)	Ω (rps)
Turns for recovery	

NATIONAL ADVISORY
COMMITTEE FOR AERONAUTICS

CHART 2.- SPIN AND RECOVERY CHARACTERISTICS OF THE $\frac{1}{10}$ -SCALE MODEL OF THE MCDONNELL XP-85 AIRPLANE EQUIPPED WITH A CONVENTIONAL TAIL; SMALL HORIZONTAL TAIL INSTALLED

Normal loading (point 1 on table III and figure 10); recovery attempted by rapid full rudder reversal except as indicated (recovery attempted from, and steady-spin data presented for, rudder full-with spins); erect spins; direction of spin as indicated

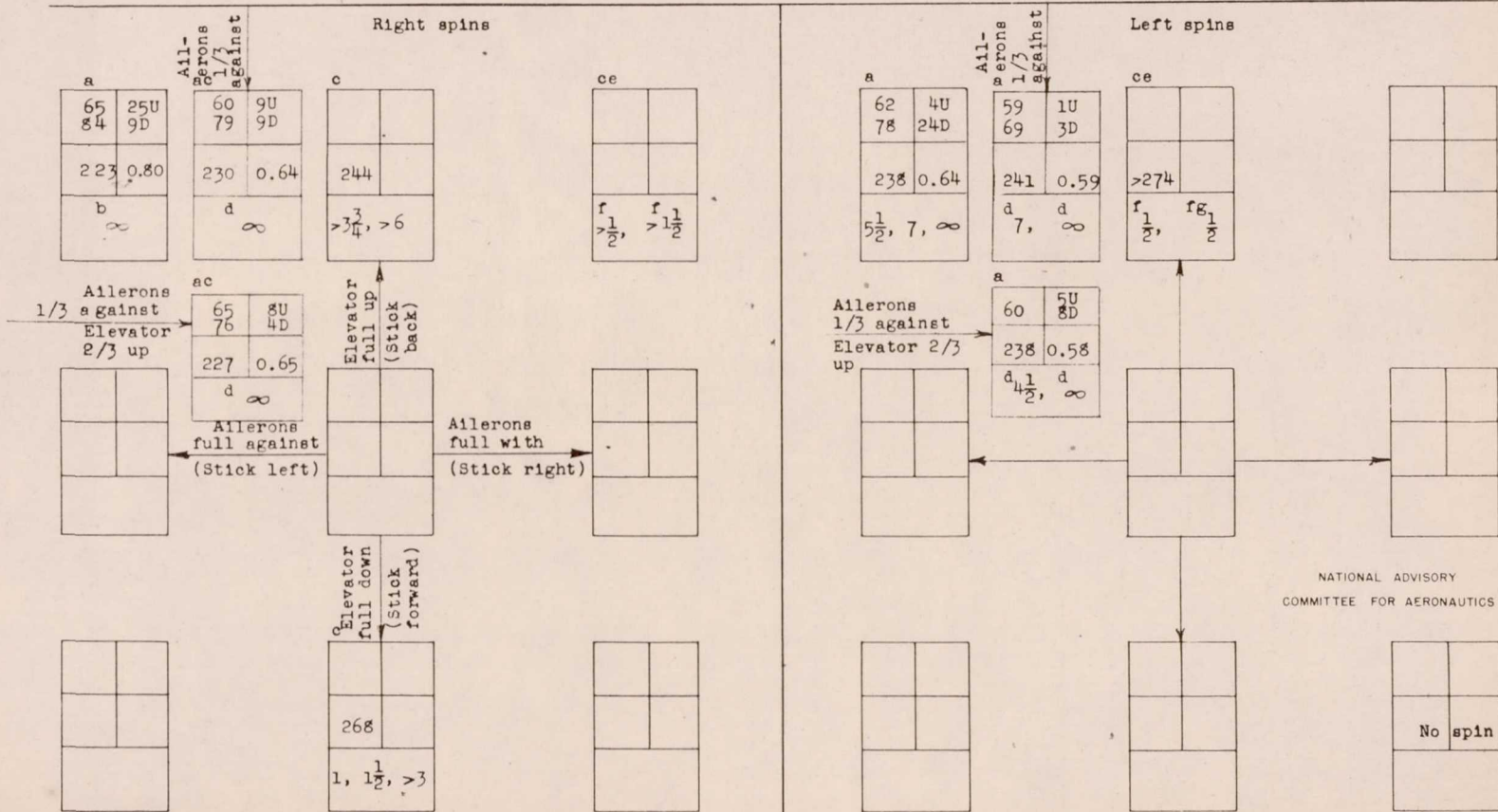

^a Oscillatory spin, range or average values given.
^b ∞ means model required more than 10 turns for recovery.
^c Wandering spin.
^d Recovery attempted by reversing rudder from full with to 2/3 against the spin.
^e Steep spin with a whip to the turning motion.
^f Recovery attempted before model reached its final steep attitude.
^g Visual observation.

Model values converted to corresponding full-scale values.
 U inner wing up
 D inner wing down

α (deg)	ϕ (deg)
V (fps)	Ω (rps)
Turns for recovery	

NATIONAL ADVISORY
 COMMITTEE FOR AERONAUTICS



CHART 3.- SPIN AND RECOVERY CHARACTERISTICS OF THE $\frac{1}{16}$ -SCALE MODEL OF THE MCDONNELL XP-85 AIRPLANE EQUIPPED WITH A CONVENTIONAL TAIL; SMALL VENTRAL FINS INSTALLED

Normal loading (point 1 on table III and figure 10); large horizontal tail installed; recovery attempted by rapid full rudder reversal except as indicated (recovery attempted from, and steady-spin data presented for, rudder full-with spins); sketches of modifications shown on figure 3); right erect spins

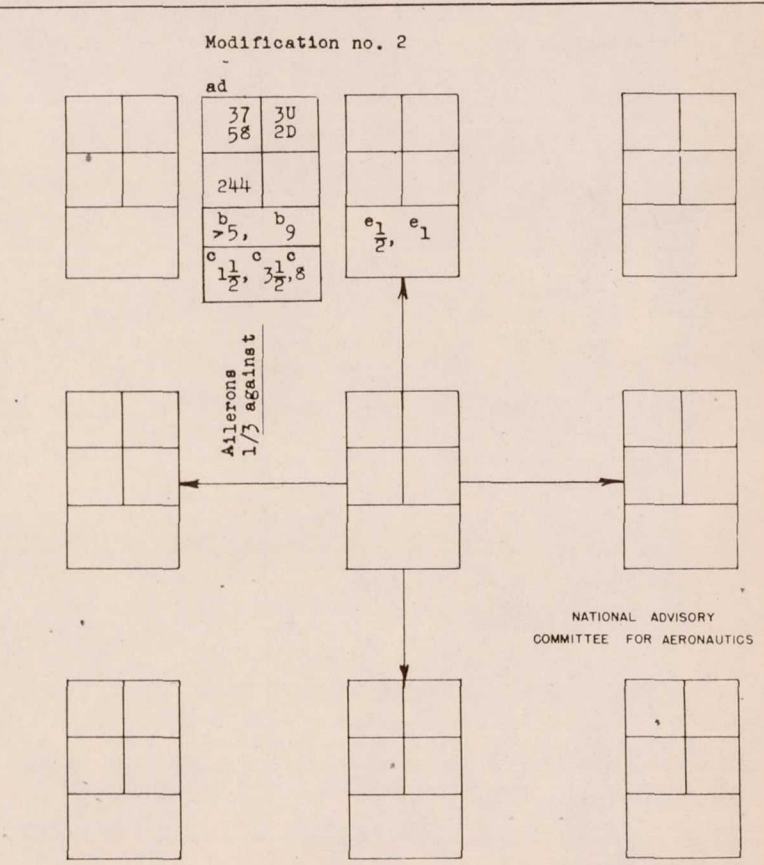
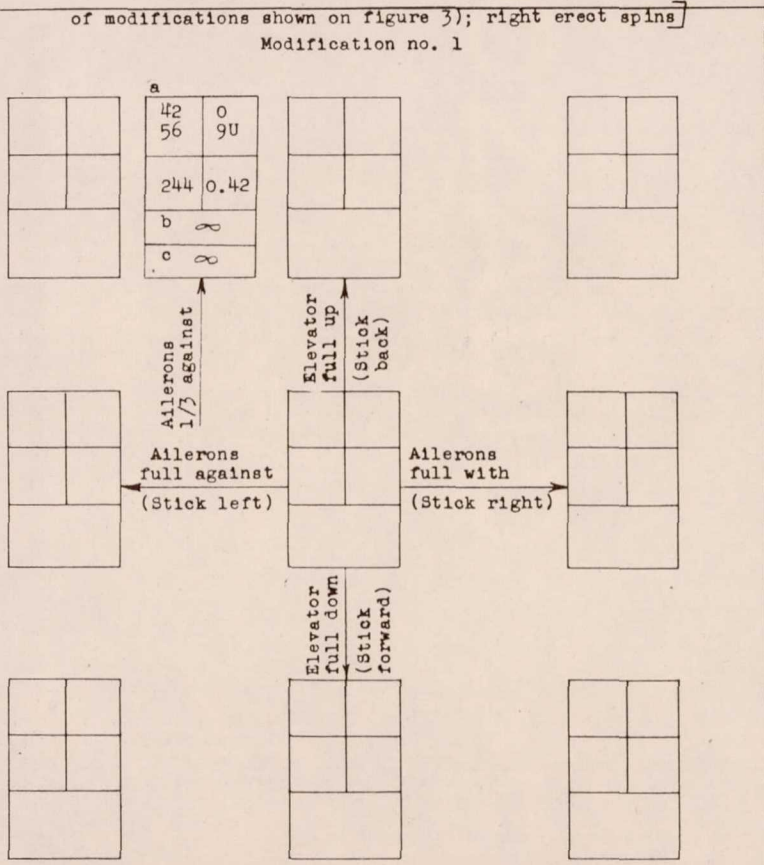

^aOscillatory spin, range or average values given.
^bRecovery attempted by reversing the rudder from full with to only 2/3 against the spin.
^cRecovery attempted by reversing the rudder from 30° with to 30° against the spin.
^dNo spin condition also obtainable.
^eVisual estimate.

Model values converted to corresponding full-scale values.
 U inner wing up
 D inner wing down

NATIONAL ADVISORY COMMITTEE FOR AERONAUTICS

a	φ
(deg)	(deg)
V	Ω
(fps)	(rps)
Turns for recovery	

CHART 4.- SPIN AND RECOVERY CHARACTERISTICS OF THE $\frac{1}{16}$ -SCALE MODEL OF THE MCDONNELL XP-85 AIRPLANE EQUIPPED WITH A CONVENTIONAL TAIL; LARGE VENTRAL FIN (12.42 SQUARE FEET, FULL SCALE) INSTALLED

Normal loading (point 1 on table III and figure 10); large horizontal tail installed; recovery attempted from, and steady-spin data presented for, rudder full-with spins); sketch of modification shown on figure 6; erect spins; direction of spin as indicated

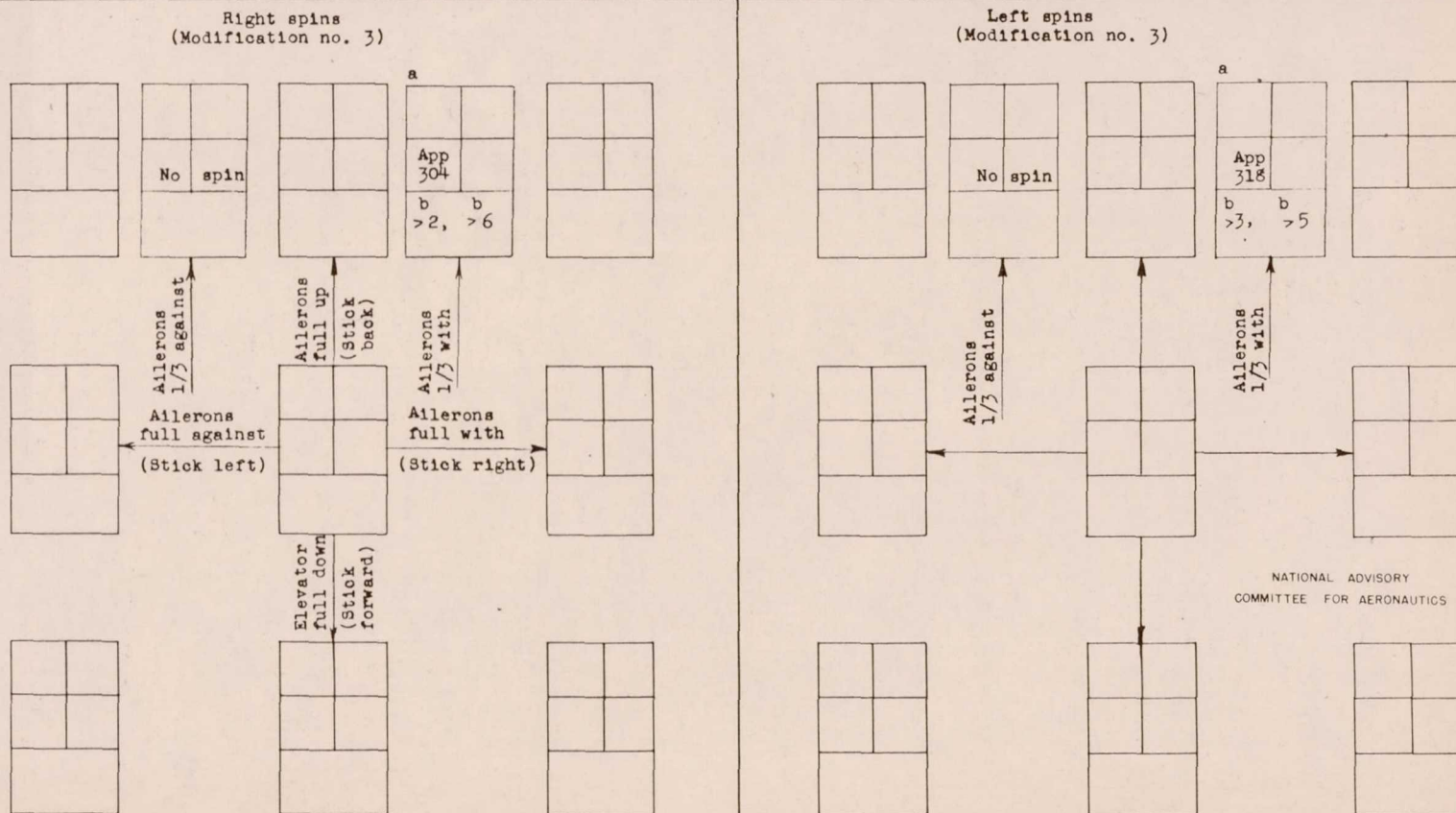

^aWandering oscillatory spin.

^bRecovery attempted by reversing the rudder from full with to 2/3 against the spin.

Model values converted to corresponding full-scale values.
U inner wing up
D inner wing down

a (deg)	φ (deg)
V (fps)	Ω (rps)
Turns for recovery	

CHART 5.- SPIN AND RECOVERY CHARACTERISTICS OF THE $\frac{1}{16}$ -SCALE MODEL OF THE MCDONNELL XP-85 AIRPLANE EQUIPPED WITH A CONVENTIONAL TAIL; HORIZONTAL TAIL RAISED TO THE TOP OF THE FIN

[Loading with horizontal tail atop fin (point 2 on table III and figure 10); large horizontal tail installed; recovery attempted by rapid full rudder reversal except as indicated (recovery attempted from, and steady-spin data presented for, rudder full-with spins); erect spins; direction of spin as indicated]

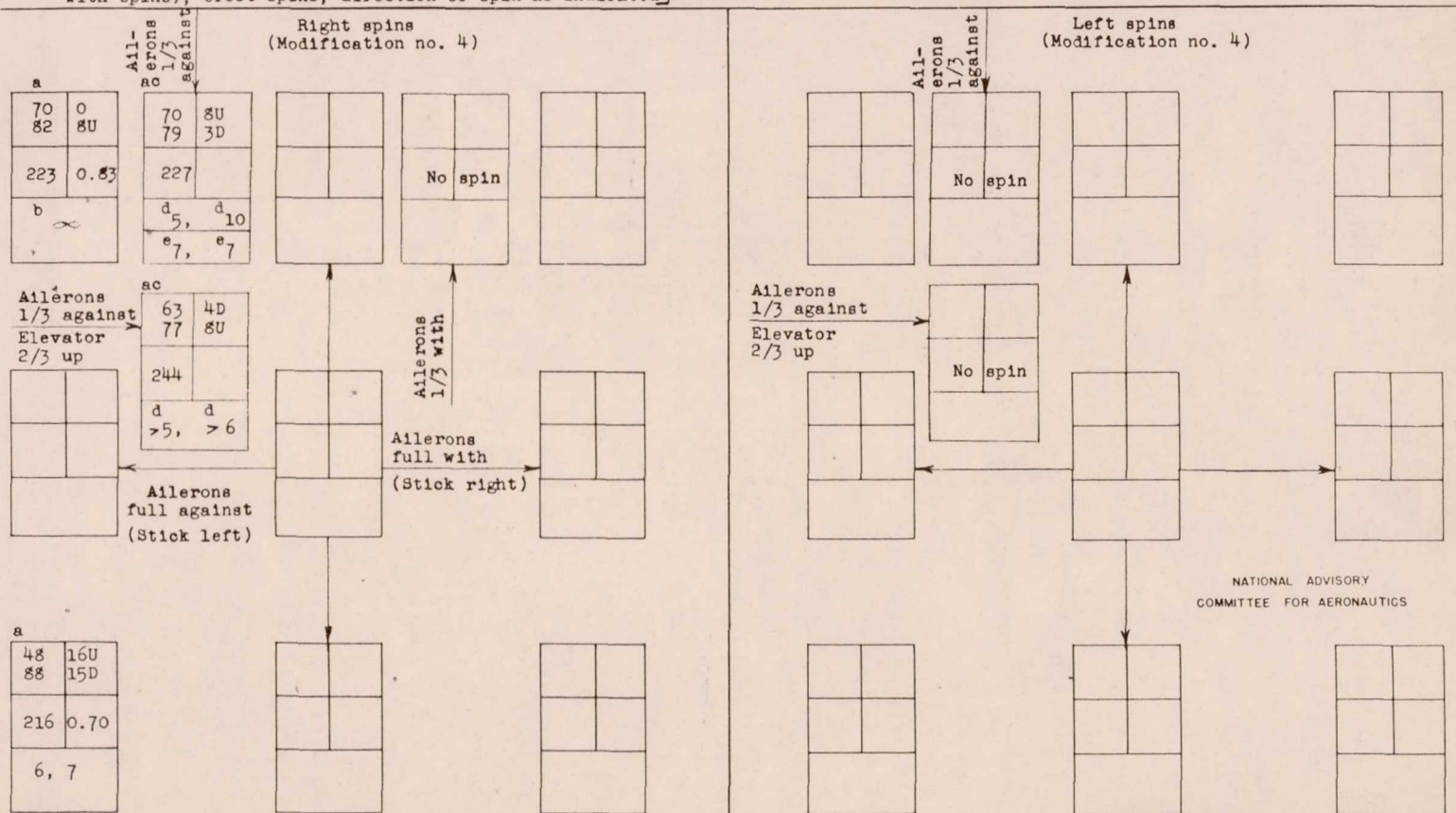

^aOscillatory spin, range or average value given.

^b ∞ means model required more than 10 turns for recovery.

^cModel does not remain in spin indefinitely but eventually dives out without reversing controls.

^dRecovery attempted by reversing rudder from full with to 2/3 against the spin.

^eRecovery attempted by simultaneous full reversal of rudder and elevator.

Model values converted to corresponding full-scale values.
U inner wing up
D inner wing down

α (deg)	ϕ (deg)
V (fps)	Ω (rps)
Turns for recovery	

NATIONAL ADVISORY
COMMITTEE FOR AERONAUTICS

CHART 6.- SPIN AND RECOVERY CHARACTERISTICS OF THE $\frac{1}{16}$ -SCALE MODEL OF THE MCDONNELL XP-55 AIRPLANE EQUIPPED WITH A CONVENTIONAL TAIL; LARGE VENTRAL FIN (17.94 SQUARE FEET, FULL SCALE) INSTALLED
 Normal loading (point 1 on table III and figure 10); large horizontal tail installed; data presented for rudder full with spins; sketch of modification shown on figure 6; erect spins; direction of spin as indicated]

NACA RM No. L7111

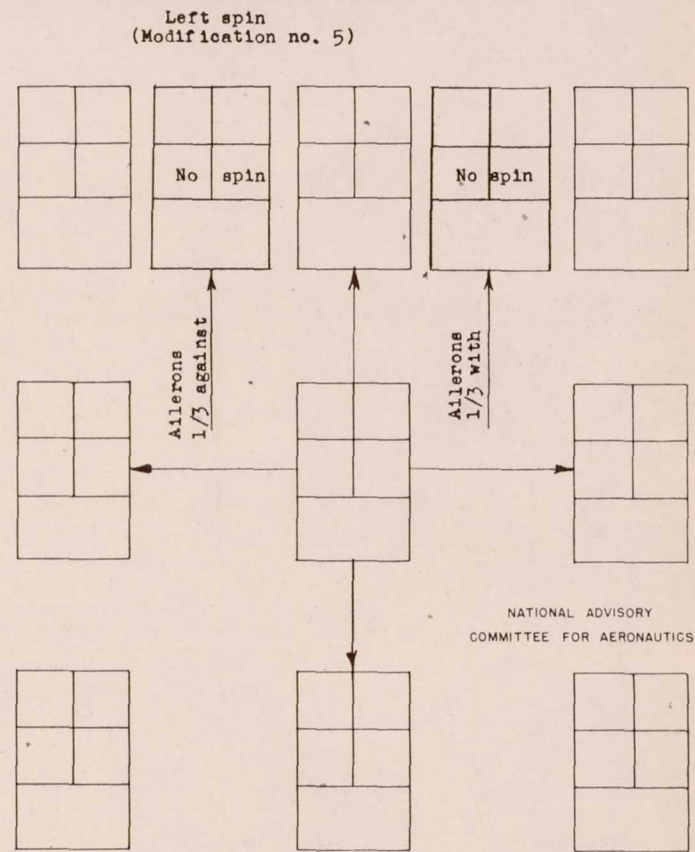
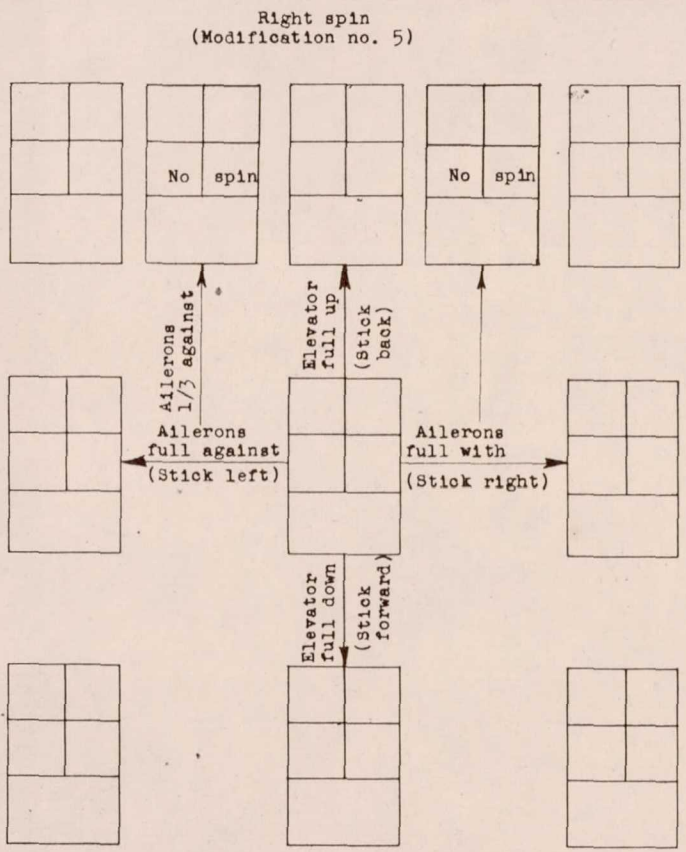

NATIONAL ADVISORY
COMMITTEE FOR AERONAUTICS

Model values converted to corresponding full-scale values.
 U inner wing up
 D inner wing down

α (deg)	ϕ (deg)
V (fps)	Ω (rps)
Turns for recovery	

CHART 7.- SPIN AND RECOVERY CHARACTERISTICS OF THE $\frac{1}{6}$ -SCALE MODEL OF THE MCDONNELL XP-85 AIRPLANE EQUIPPED WITH A CONVENTIONAL TAIL; SIDES OF THE FUSELAGE REARWARD OF THE WING TRAILING EDGE FLATTENED AND NARROWED

[Normal loading; large horizontal tail installed; recovery attempted by rapid full rudder reversal except as indicated (recovery attempted from, and steady-spin data presented for, rudder full-with spines); erect spins; direction of spin as indicated]

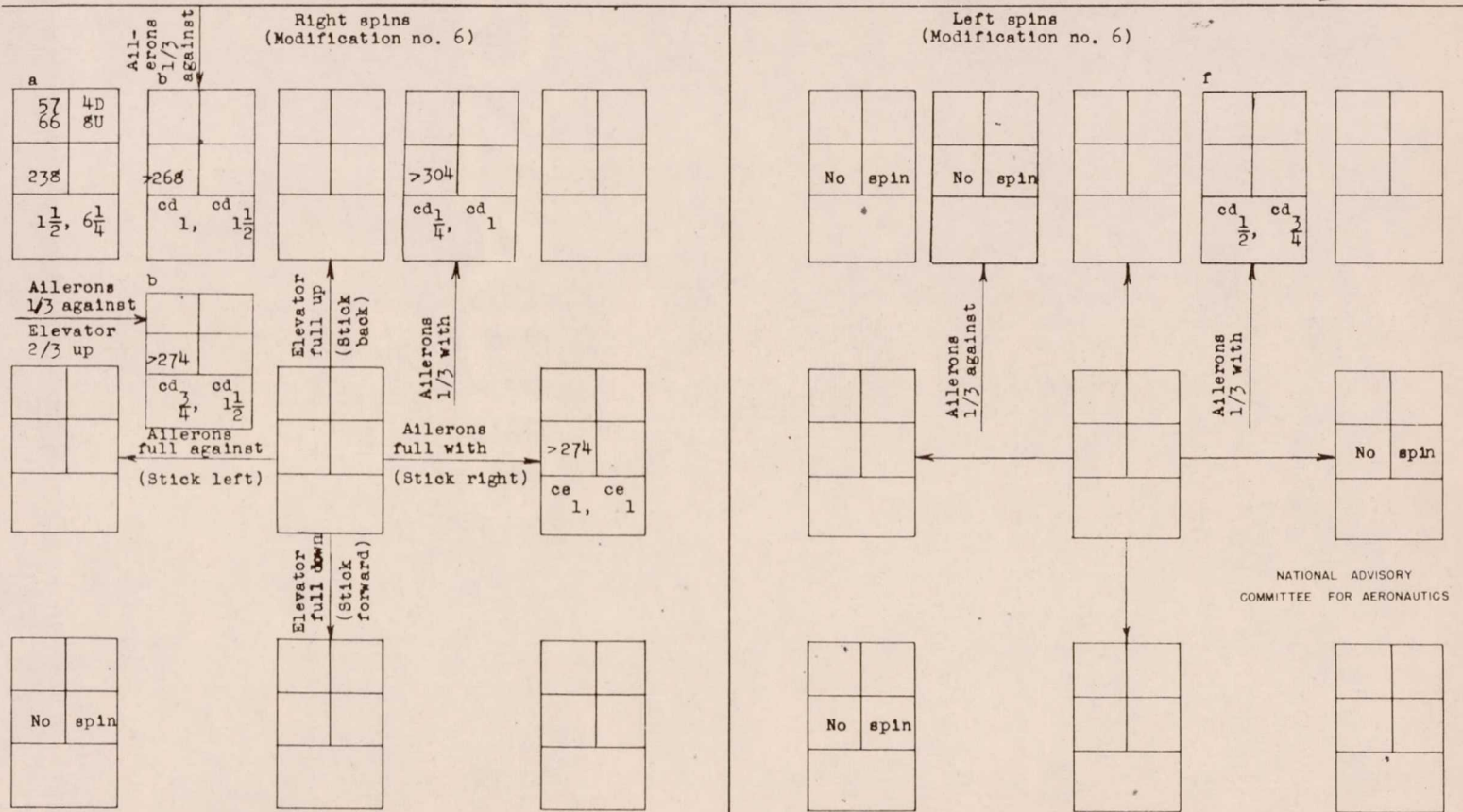

- a Oscillatory spin, range or average values given.
- b Wandering spin.
- c Recovery attempted before model reached its final steep attitude.
- d Recovery attempted by reversing the rudder from full with to 2/3 against the spin.
- e Model goes into a vertical roll upon recovery.
- f Radius of spin increases as spin progresses.

Model values converted to corresponding full-scale values.
 U inner wing up
 D inner wing down

a (deg)	ϕ (deg)
V (fps)	Ω (rps)
Turns for recovery	

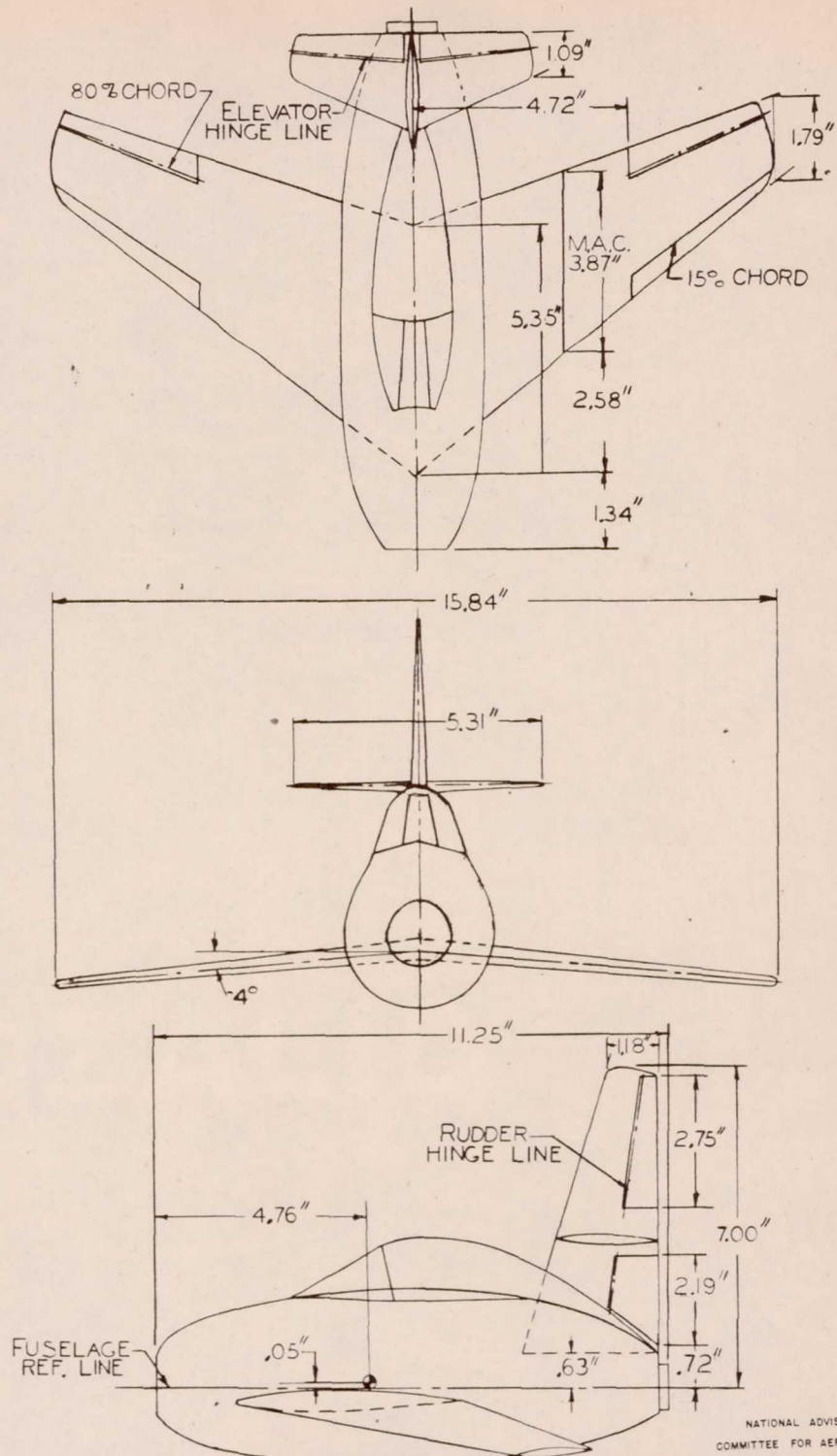

NATIONAL ADVISORY
COMMITTEE FOR AERONAUTICS

FIGURE 1. THREE-VIEW DRAWING OF THE $\frac{1}{16}$ -SCALE MODEL OF THE MCDONNELL XP-85 AIRPLANE WITH THE CONVENTIONAL TAIL ARRANGEMENT AS TESTED IN THE 20-FOOT FREE-SPINNING TUNNEL. CENTER OF GRAVITY SHOWN FOR NORMAL LOADING. LARGE HORIZONTAL TAIL INSTALLED.

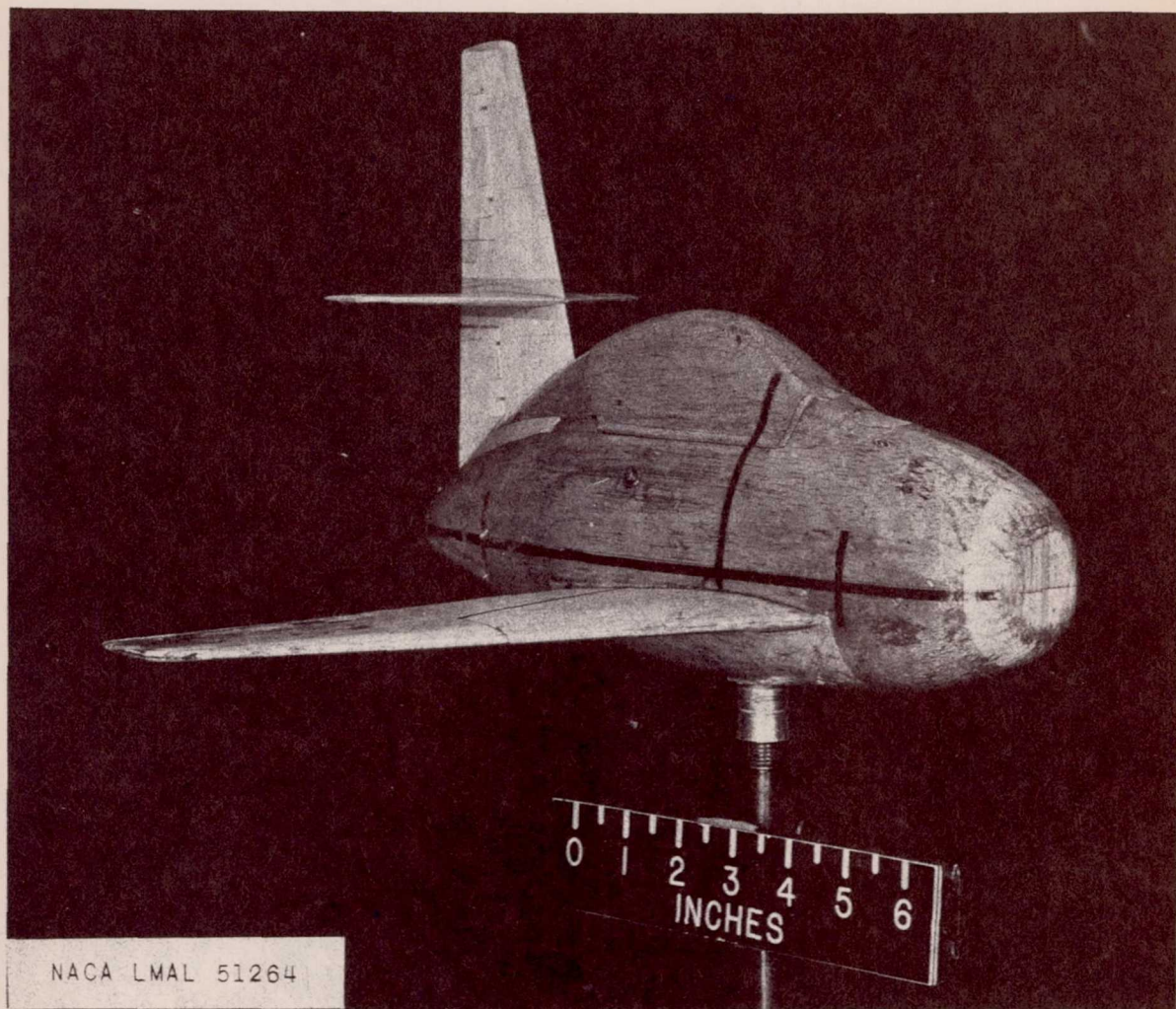
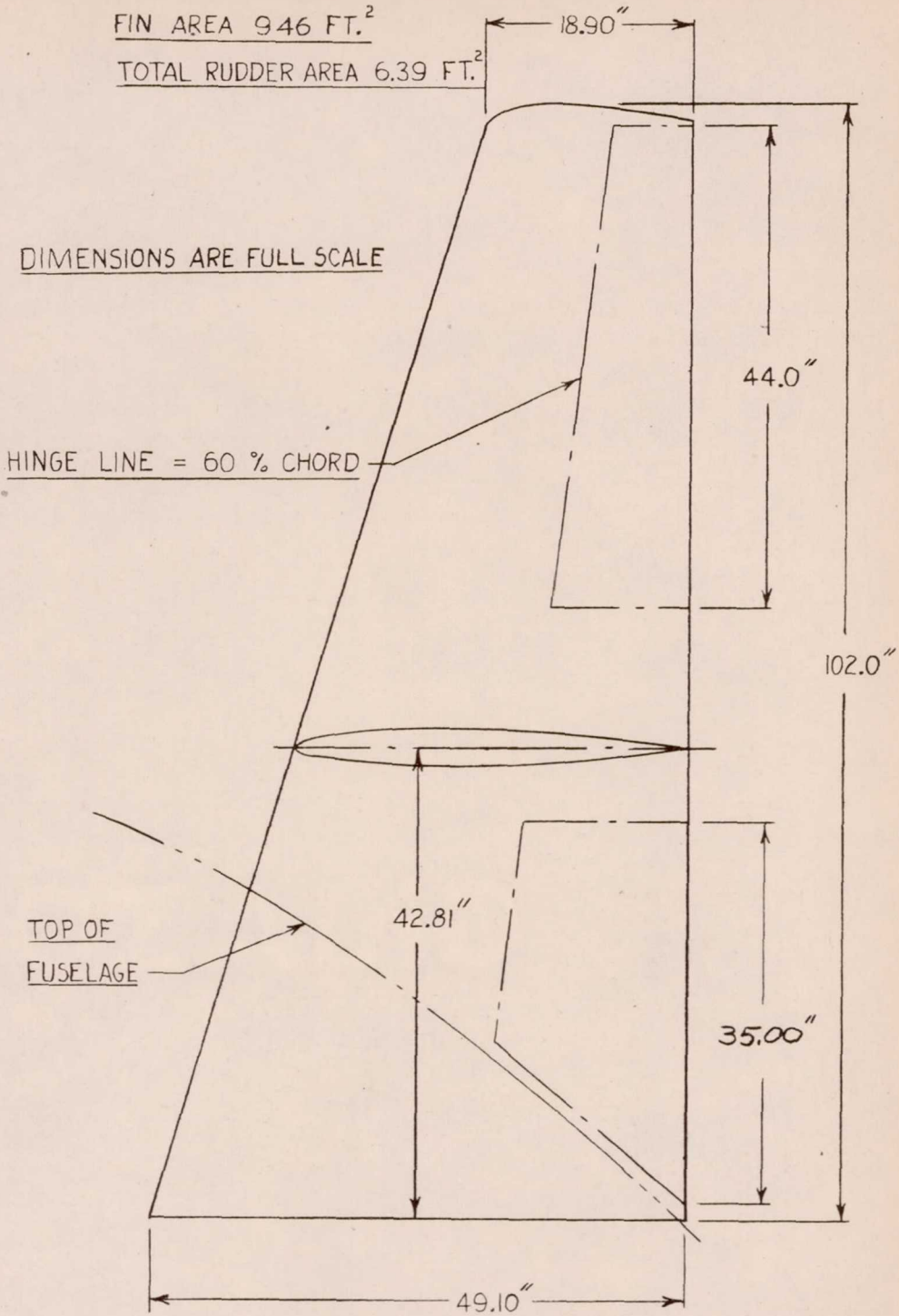

Figure 2.- The $\frac{1}{16}$ -scale model of the McDonnell XP-85 airplane with the conventional tail arrangement.

AIRFOIL SECTION NACA 66-009

FIN AREA 946 FT.²

TOTAL RUDDER AREA 6.39 FT.²



NATIONAL ADVISORY
COMMITTEE FOR AERONAUTICS

FIGURE 3.- CONVENTIONAL VERTICAL TAIL TESTED ON THE $\frac{1}{16}$ -SCALE MODEL OF THE MC DONNELL XP-85 AIRPLANE.

AIRFOIL SECTION NACA 66-009

AREA TAIL ① 13.22 FT.²

AREA TAIL ② 15.96 FT.²

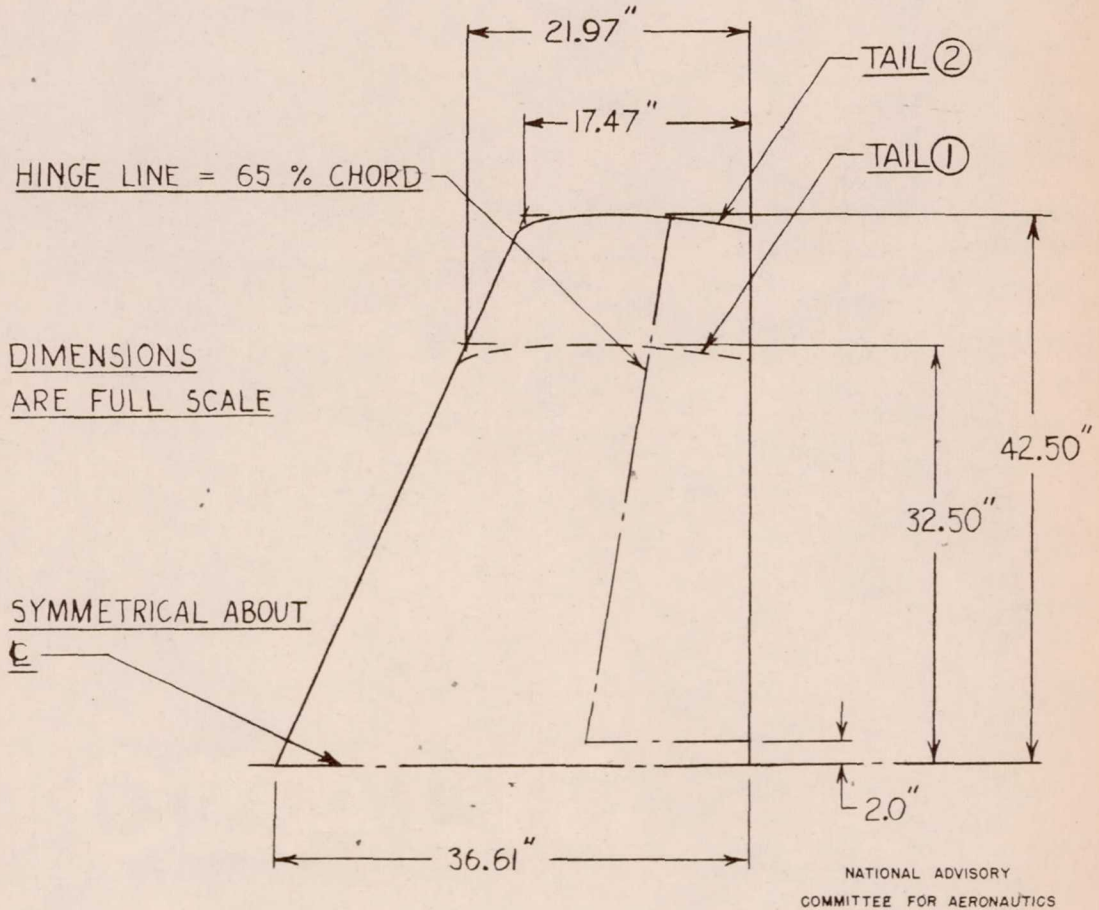
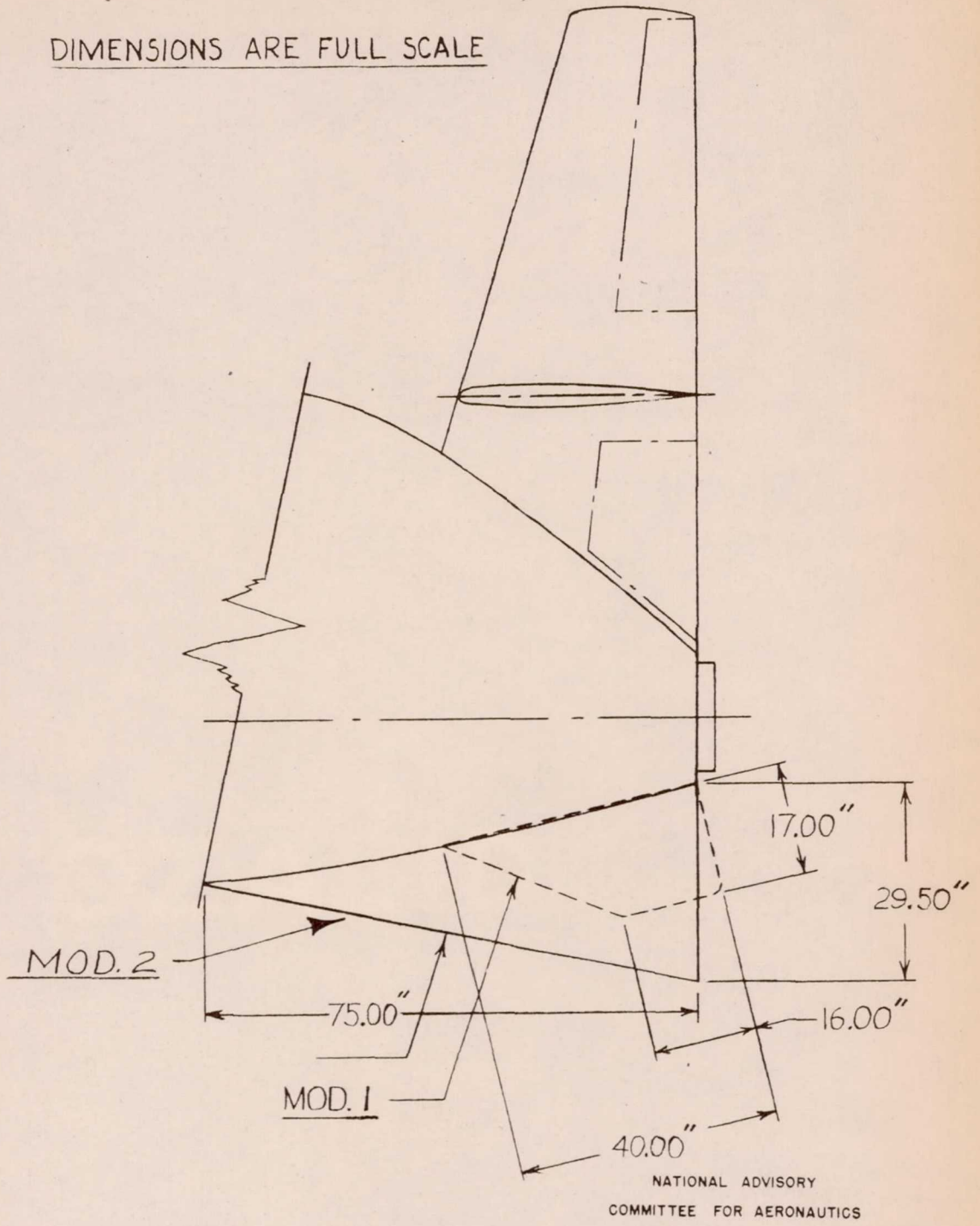

FIGURE 4. - HORIZONTAL TAILS TESTED ON THE 1/16-SCALE MODEL OF THE MC DONNELL XP-85 AIRPLANE.

DIMENSIONS ARE FULL SCALE



NATIONAL ADVISORY
COMMITTEE FOR AERONAUTICS

FIGURE 5. - VENTRAL FINS TESTED ON THE $\frac{1}{16}$ SCALE
MODEL OF THE MC DONNELL XP-85 AIRPLANE

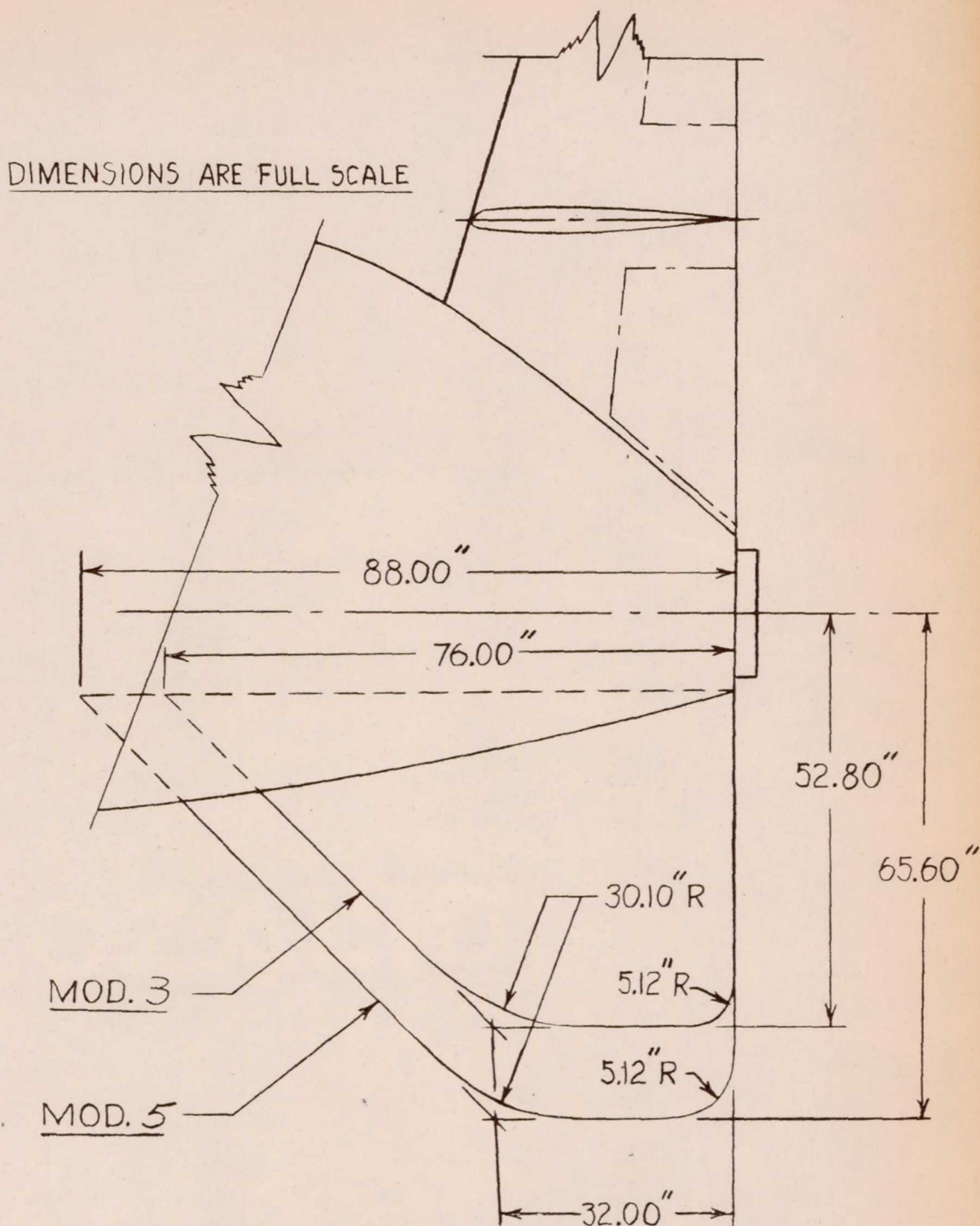

NATIONAL ADVISORY
COMMITTEE FOR AERONAUTICS

FIGURE 6. - VENTRAL FINS TESTED ON THE $\frac{1}{16}$ -SCALE MODEL OF THE MC DONNELL XP-85 AIRPLANE.

DIMENSIONS ARE
FULL SCALE

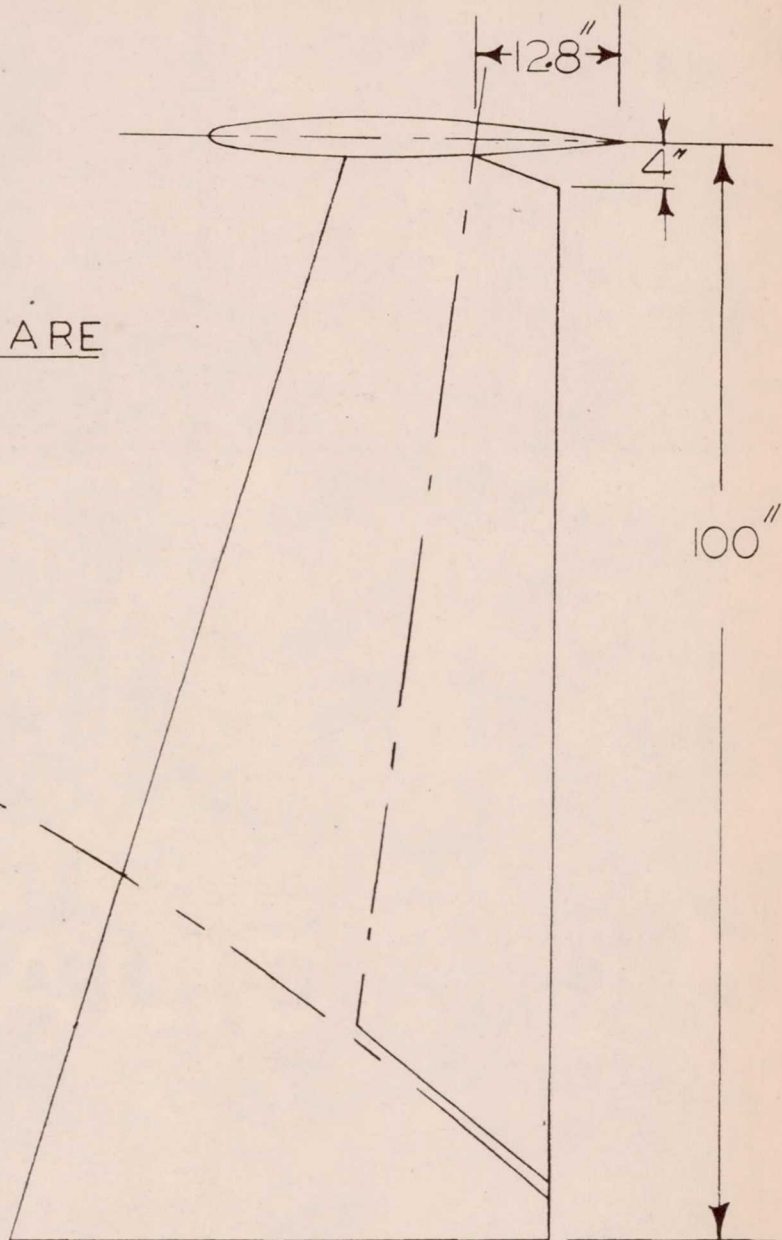

NATIONAL ADVISORY
COMMITTEE FOR AERONAUTICS

FIGURE 7. - MODIFICATION 4 (LARGE HORIZON-
TAL TAIL ATOP FIN) TESTED ON THE 1/16-
MODEL OF THE MCDONNELL XP-85 AIR-
PLANE.

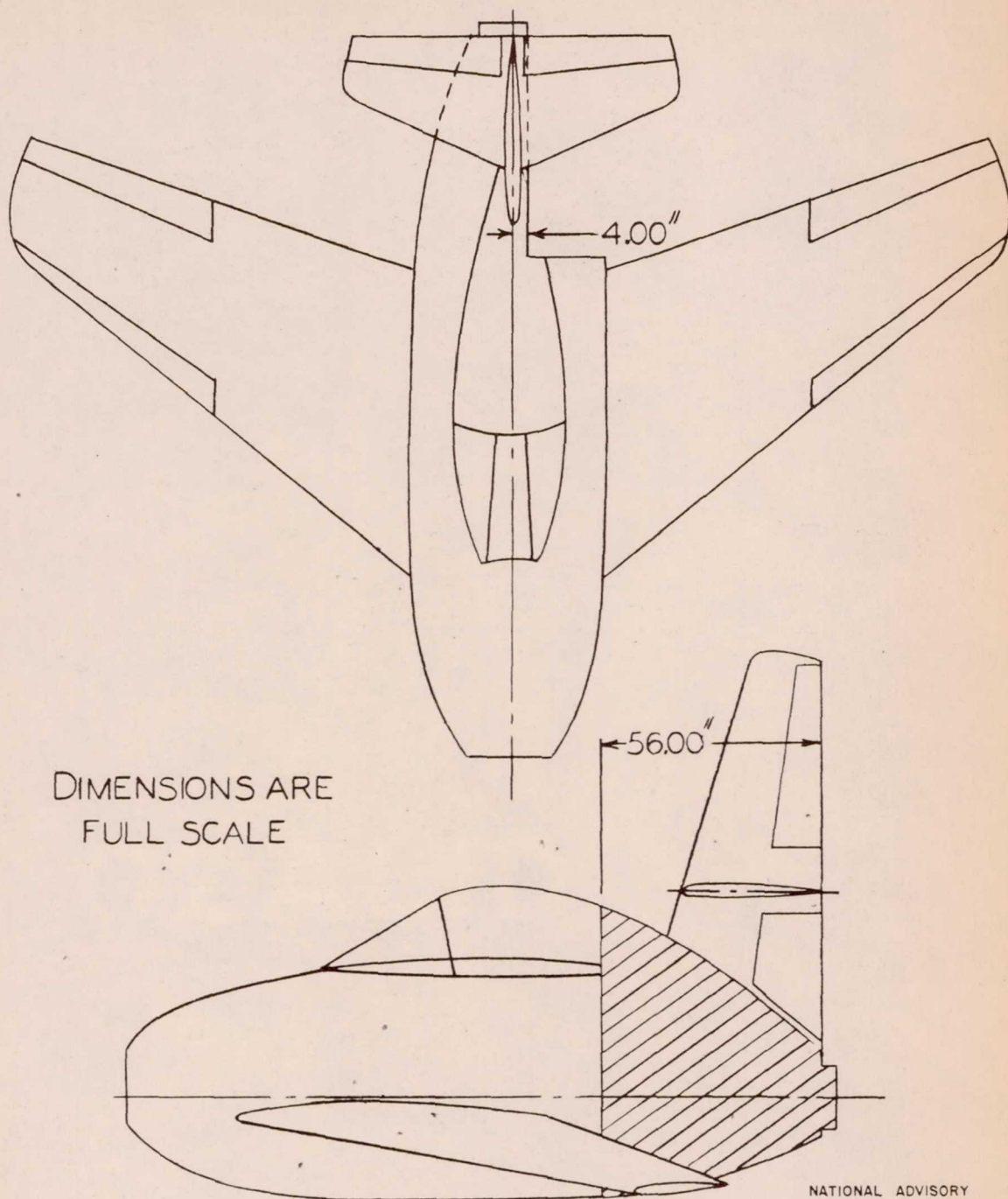

FIGURE 8.—MODIFICATION 6 SHOWING THE LEFT REAR SIDE OF THE FUSELAGE CUT AWAY AS TESTED FOR THE RIGHT SPINS ON THE $\frac{1}{16}$ -SCALE MODEL OF THE McDONNELL XP-85 AIRPLANE.

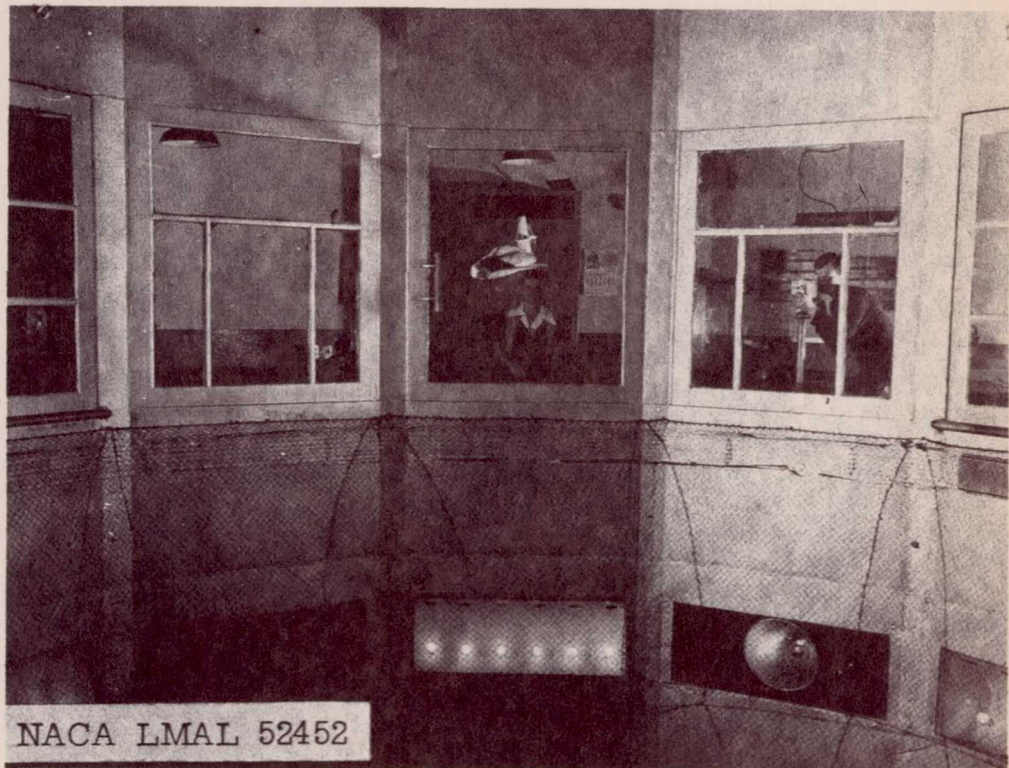

Figure 9.- Photograph of the $\frac{1}{16}$ - scale model of the McDonnell XP-85 airplane with the conventional tail arrangement spinning in the Langley 20-foot free-spinning tunnel.

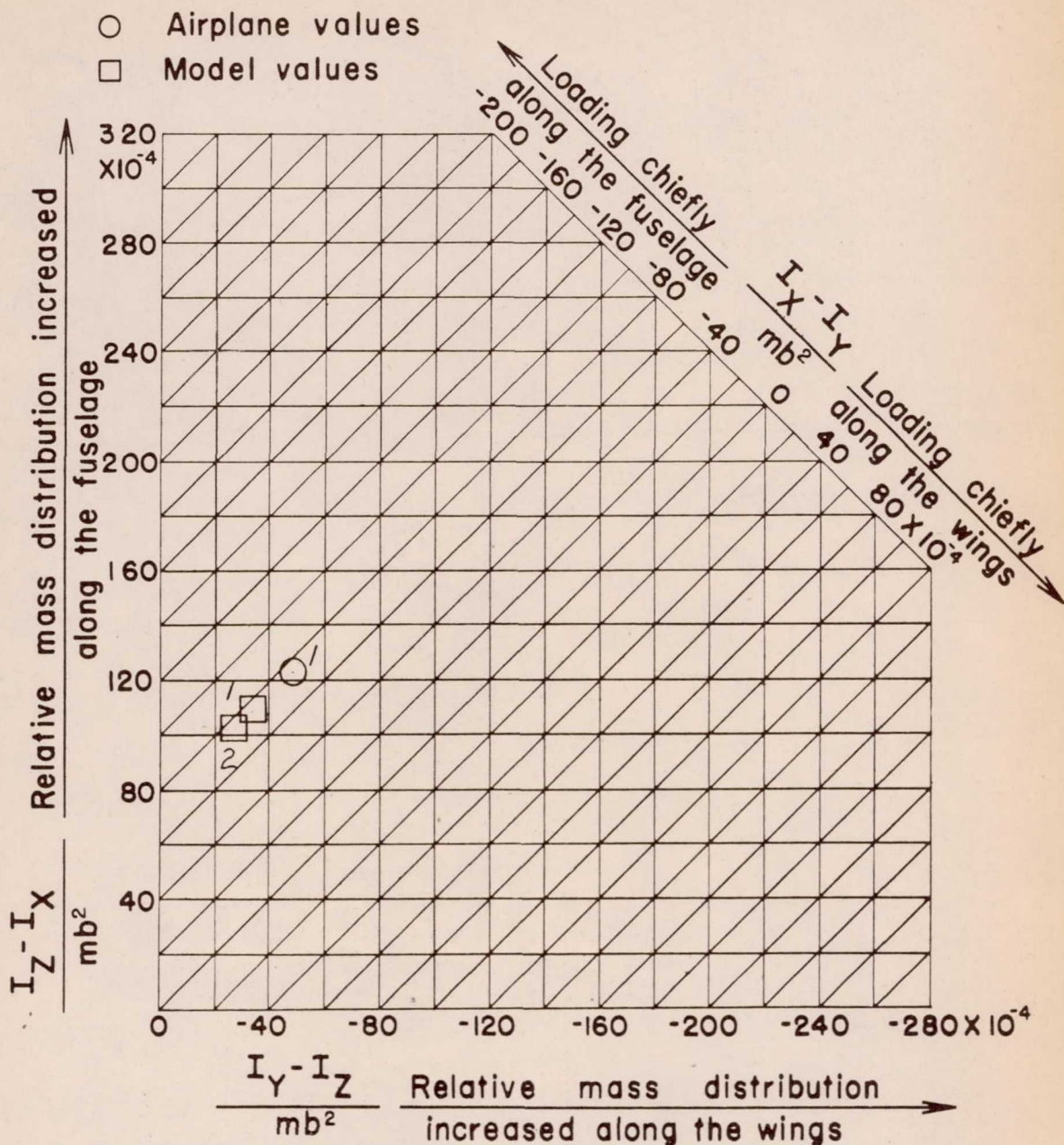

FIGURE 10. - MASS PARAMETERS FOR THE LOADINGS TESTED ON THE MODEL AND FOR THE NORMAL LOADING FOR THE XP-85 AIRPLANE. (POINTS ARE FOR LOADINGS LISTED ON TABLE III.)