

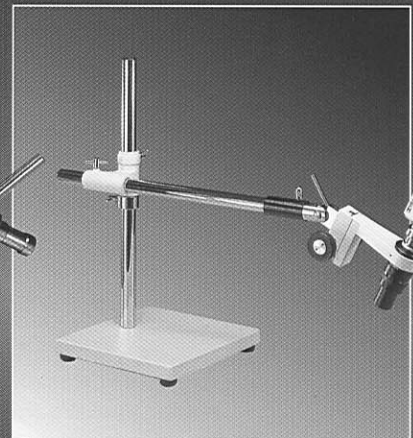

SHORT "UNIMAC" Series

MACROZOOM LENSES

Direct Video Short Back-Focus Zoom Lens System

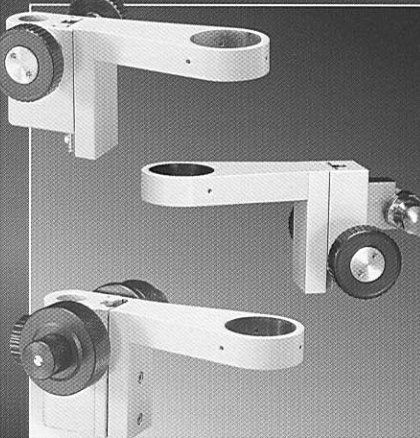
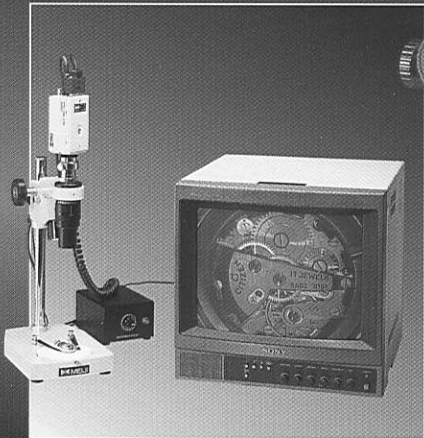

SHORT "UNIMAC" Series

MACROZOOM LENSES

The Short "UNIMAC" Series of high-performance, direct, zoom lens systems have been specifically designed to provide high quality, low power images with excellent resolution and exceptional depth of field at extended working distances.

The Short "UNIMAC" Series of macrozoom lenses couple directly to a CCD video camera and allows the macrozoom lenses to maintain a very short profile facilitating use in situations where space is restricted. These versatile and modular lens systems are ideally suited for a variety of free standing and OEM applications.

Superb optical quality and mechanical flexibility allow the user to cover a wide spectrum of viewing needs. A variety of auxiliary lenses, focus blocks, illumination systems, digital camera adapters and other components allow you to easily customize the system for your specific situation.

The Short "UNIMAC" Series lenses have a 6.4 : 1 zoom ratio and maintain parfocality throughout their extended zoom range. The Short "UNIMAC" lenses are available in either a standard zoom configuration or a detent zoom configuration, which is useful for calibration and measurement purposes.



MS-35 · MS-35D



MS-40 · MS-40D



MS-45 · MS-45D



MS-50 · MS-50D

SHORT "UNIMAC" MACROZOOM LENSES

Cat. No.	Description	Zoom Ratio	W.D.
MS-35	0.22X - 1.4X with "C" mount adapter	6.4 : 1	173mm
MS-40	0.28X - 1.8X with "C" mount adapter	6.4 : 1	94mm
MS-45	0.41X - 2.6X with "C" mount adapter	6.4 : 1	94mm
MS-50	0.7X - 4.5X with "C" mount adapter	6.4 : 1	94mm

SHORT "UNIMAC" MACROZOOM LENSES WITH DETENT

Cat. No.	Description	Zoom Ratio	W.D.
MS-35D	0.22X - 1.4X with "C" mount adapter	6.4 : 1	173mm
MS-40D	0.28X - 1.8X with "C" mount adapter	6.4 : 1	94mm
MS-45D	0.41X - 2.6X with "C" mount adapter	6.4 : 1	94mm
MS-50D	0.7X - 4.5X with "C" mount adapter	6.4 : 1	94mm

W.D. : Working Distance

NOTE: SHORT "UNIMAC" Detent lenses provide discrete detent positions in the zoom travel. The discrete detent positions allow the end user to make exact system calibrations with a repeatability of $\pm 03\%$ error.

DIMENSIONAL ILLUSTRATIONS

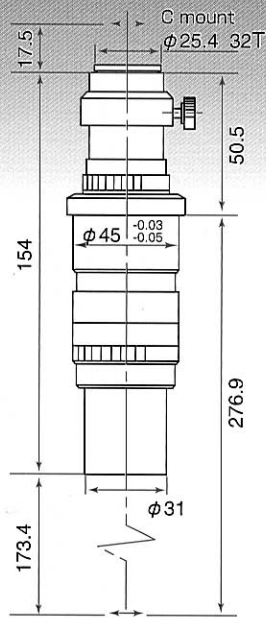

MS-35 · MS-35D

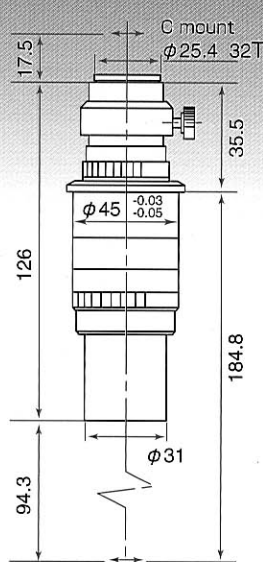

MS-40 · MS-40D

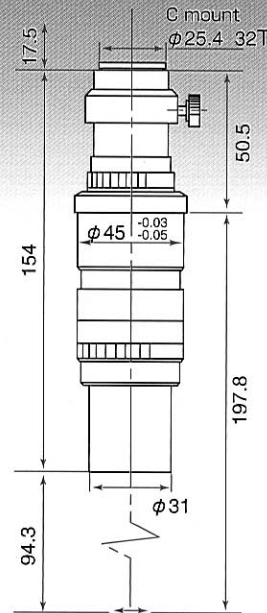

MS-45 · MS-45D

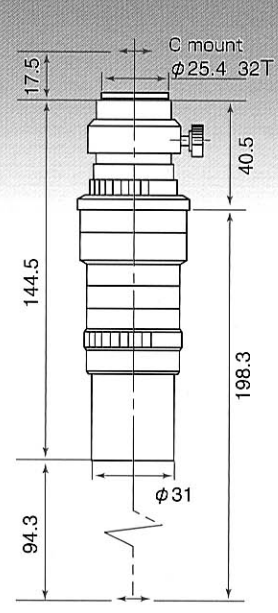

MS-50 · MS-50D

AUXILIARY LENSES

Auxiliary lenses are used to change the working distance, magnification and field of view of the main direct video lens. Four auxiliary lenses are available. The MS-6 and MS-7 are used to reduce magnification and increase working distance. The MS-8 and MS-9 are used to increase magnification and decrease working distance.

Cat.No.	Description
MS-6	Auxiliary lens 0.5X
MS-7	Auxiliary lens 0.75X
MS-8	Auxiliary lens 1.5X

Cat.No.	Description
MS-9	Auxiliary lens 2.0X
MS-17	Rotatable polarizer
MS-24	Protective glass for MS-50 (For use without auxiliary lenses)

MACROZOOM SYSTEMS WITH DETENT

The Short "UNIMAC" Series of direct video lenses are available with discrete factory pre-set detent stops. The detent system allows for repeatability and calibration to various standards when used in measuring applications. The factory pre-set stops are located at each marked magnification of the zoom range. Calibration of the lens system is achieved by using an adapter with 1.0X magnification factor (MA155/10/15) and inserting a reticle into it, which allows the reticle image to be projected onto the TV monitor. The lens system can then be calibrated against a known standard (stage micrometer) at each position of detent. The following reticle and calibration scale is recommended:

MA280

Eyepiece Micrometer,
(10mm divided into 100 units,
19mm diameter) is recommended.

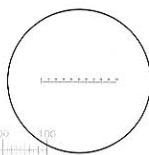

MA184

Calibration Scale
(25mm cross-line with 0.1mm
graduations, numbered 0-250,
30mm diameter) is recommended.

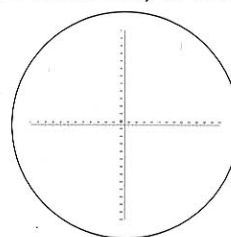

CALCULATING THE FIELD-OF-VIEW ON YOUR TV MONITOR

The field of view on your TV monitor is dependent upon the following three factors:

- Camera Format (Size of the CCD Chip)
- Zoom Objective Magnification
- Video "C" Mount Magnification

The visible portion of your specimen does not fluctuate with an increase or decrease in the size of your TV monitor. The field-of-view on your TV monitor can be determined through the following calculations :

$$\frac{\text{Monitor Field of View (Height, Width or Diagonal)}}{\text{CCD Chip Size (height, width or diagonal)}} = \text{Objective Mag.} \times \text{Auxiliary Lens Mag.} \times \text{Video "C" Mount Mag.}$$

When calculating the zoom objective magnification remember to include the magnification factor of any auxiliary lens attached to your main objective lens. The following table lists common CCD chip dimensions.

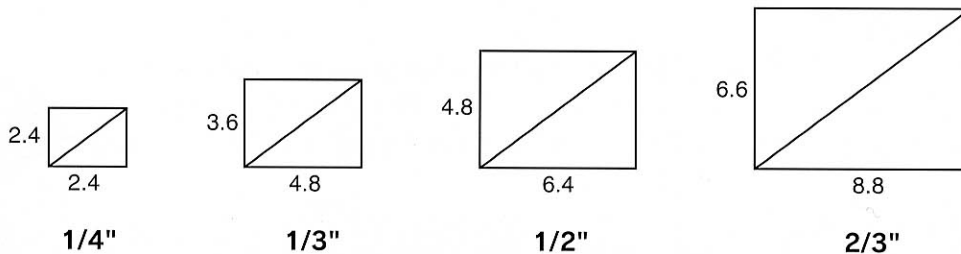

Camera Format	Height	Width	Diagonal
1/4"	2.4mm	3.2mm	4mm
1/3"	3.6mm	4.8mm	6mm
1/2"	4.8mm	6.4mm	8mm
2/3"	6.6mm	8.8mm	11mm

Example : Determine the field of view on the TV monitor using the MS-50 Macrozoom objective (0.7X~4.5X), a 0.5X auxiliary lens and a 1/2" chip CCD camera.

1. First locate the 1/2" CCD chip dimensions from the table above.
Height : 4.8mm, Width: 6.4mm, Diagonal: 8.0mm
2. Determine the optical magnification : Zoom Mag. x Auxiliary Lens Mag. x "C" Mount Mag.
Magnification : (0.7X~4.5X) x (0.5X) x (1X) = 0.35X~2.25X
3. Calculate the specimen field height and width :
Field Height = 4.8mm / (0.35X~2.25X) = 13.71mm~2.13mm
Field Width = 6.4mm / (0.35X~2.25X) = 18.29mm~2.84mm
Field Diagonal = 8.0mm / (0.35X~2.25X) = 22.86mm~3.56mm

TABLE OF MAGNIFICATION, NUMERICAL APERTURE, DEPTH OF FIELD AND FIELD OF VIEW

Cat.No.	Auxiliary Lens	MS-35 · MS-35D	W.D.	MS-40 · MS-40D	W.D.	MS-45 · MS-45D	W.D.	MS-50 · MS-50D	W.D.
		Low - High		Low - High		Low - High		Low - High	
0.5X	N.A.	***	182 mm	0.014 - 0.034	182 mm	0.014 - 0.034	182 mm	0.014 - 0.035	182 mm
	MAG	***		0.14X - 0.90X		0.21X - 1.30X		0.35X - 2.25X	
	D.O.F.	***		3.0 - 0.47		2.9 - 0.47		3.28 - 0.48	
	F.O.V.1/4"	***		22.84×17.14 3.50×2.66		15.6×11.7 2.46×1.84		6.56×6.84 1.42×1.066	
	F.O.V.1/3"	***		34.2×256 5.2×4.0		23.4×17.4 3.6×3.0		13.6×10.2 2.0×1.6	
	F.O.V.1/2"	***		45.6×34 7×5.2		31.2×23.4 48×3.6		18.2×13.2 2.8×2.0	
	F.O.V.2/3"	***		62.84×47.14 9.76×7.32		42.92×32.18 6.75×5.0		25.14×18.84 3.9×2.92	
0.75X	N.A.	***	105 mm	0.020 - 0.051	105 mm	0.020 - 0.051	105 mm	0.020 - 0.053	105 mm
	MAG	***		0.21X - 1.36X		0.31X - 1.95X		0.53X - 3.38X	
	D.O.F.	***		1.3 - 0.21		1.3 - 0.21		1.46 - 0.21	
	F.O.V.1/4"	***		15.22×11.42 2.36×1.77		10.4×7.8 1.64×1.22		4.37×4.56 0.94×0.71	
	F.O.V.1/3"	***		22.8×17.0 3.46×2.66		15.6×11.6 2.4×2.0		9.06×6.8 1.33×1.06	
	F.O.V.1/2"	***		30.4×22.66 4.66×3.46		20.8×15.6 3.2×2.4		12.13×9.06 1.86×1.33	
	F.O.V.2/3"	***		41.89×31.42 6.5×4.88		28.61×21.45 4.5×3.37		16.76×12.56 2.6×1.94	
NONE	N.A.	0.015 - 0.038	173 mm	0.027 - 0.068	94 mm	0.027 - 0.069	94 mm	0.027 - 0.07	94 mm
	MAG	0.22X - 1.4X		0.28X - 1.8X		0.41X - 2.6X		0.7X - 4.5X	
	D.O.F.	2.4 - 0.38		0.74 - 0.12		0.73 - 0.12		0.82 - 0.12	
	F.O.V.1/4"	14.54×10.9 2.28×1.75		11.42×8.57 1.77×1.33		7.8×5.85 1.23×0.92		3.28×3.42 0.7×0.533	
	F.O.V.1/3"	21.8×16.3 3.4×2.5		17.1×12.8 2.6×2.0		11.7×8.7 1.8×1.5		6.8×5.1 1.0×0.8	
	F.O.V.1/2"	29.0×21.8 4.5×3.4		22.8×17.0 3.5×2.6		15.6×11.7 2.4×1.8		9.1×6.8 1.4×1.0	
	F.O.V.2/3"	40×30 6.28×4.71		31.42×23.57 4.88×3.66		21.46×16.09 3.38×2.53		12.57×9.42 1.95×1.46	
1.5X	N.A.	***	44 mm	0.040 - 0.102	44 mm	0.040 - 0.103	44 mm	0.040 - 0.105	44 mm
	MAG	***		0.42X - 2.70X		0.62X - 3.90X		1.05X - 6.75X	
	D.O.F.	***		0.33 - 0.052		0.33 - 0.052		0.36 - 0.08	
	F.O.V.1/4"	***		7.81×5.71 1.18×0.88		5.2×3.9 0.82×0.61		2.18×2.28 0.47×0.35	
	F.O.V.1/3"	***		11.4×8.53 1.73×1.33		7.8×5.8 1.2×1.0		4.53×3.4 0.66×0.53	
	F.O.V.1/2"	***		15.2×8.53 1.73×1.33		10.4×7.8 1.6×1.2		6.06×4.53 0.93×0.66	
	F.O.V.2/3"	***		20.94×15.71 3.25×2.44		14.30×10.72 2.25×1.68		8.38×6.28 1.3×1.84	
2.0X	N.A.	***	29 mm	0.054 - 0.136	29 mm	0.054 - 0.138	29 mm	0.054 - 0.14	29 mm
	MAG	***		0.56X - 3.60X		0.82X - 5.20X		1.40X - 9.0X	
	D.O.F.	***		0.18 - 0.029		0.18 - 0.029		0.21 - 0.03	
	F.O.V.1/4"	***		5.71×4.28 0.88×0.66		3.9×2.92 0.61×0.46		1.64×1.74 0.35×0.26	
	F.O.V.1/3"	***		8.55×6.4 1.3×1.0		5.85×4.35 0.9×0.75		3.4×2.55 0.5×0.4	
	F.O.V.1/2"	***		11.4×8.5 1.75×1.3		7.8×5.85 1.2×0.9		4.5×3.4 0.7×0.5	
	F.O.V.2/3"	***		15.71×11.78 2.44×1.86		10.73×8.04 1.69×1.26		6.28×4.71 0.97×0.73	

*** Indicates vignetting

W.D: Working Distance

N . A . : Numerical Aperture-Numerical aperture is a measure of the light gathering ability of the lens system and determines the resolving power and depth of field of the lens. Numerical aperture is often symbolized by the letters N.A.and is expressed as a number.

MAG . : Optical Magnification of the objective lens system.

D.O.F : Depth of Field-The distance on both sides of the object plane through which satisfactory definition can be maintained when the object is moved without a detectable loss of sharpness in the image.

F.O.V. : Field of View (Height and Width) stated in millimeters.

CALCULATING TOTAL ON-SCREEN MAGNIFICATION OF YOUR TV MONITOR

The total on-screen magnification of your TV monitor is the product of both optical magnification and electronic magnification. The optical magnification is the objective magnification times the magnification of the adapter times the magnification of any attached auxiliary lens. The electronic magnification is the product of the diagonal dimension of the TV monitor in millimeters divided by the diagonal dimension of the CCD camera chip in millimeters. The chart below details common electronic magnifications for various video monitors and CCD camera formats. The total on screen magnification can be calculated by applying the following formula:

$$\text{Total On-Screen Magnification} = \text{Optical Magnification} \times \text{Electronic Magnification}$$

Electronic Magnification Table

Video Monitor Screen Size (Diagonal)						
Chip Format	9"	12"	13"	19"	20"	27"
1/4"	57.2X	76.2X	82.6X	120.7X	127X	171.5X
1/3"	38.1X	50.8X	55.0X	80.4X	84.7X	114.3X
1/2"	28.6X	38.1X	41.3X	60.3X	63.5X	85.7X
2/3"	20.8X	27.7X	30.0X	43.9X	46.2X	62.3X

Example: Determine the on-screen magnification when using the MS-50 macrozoom objective, a 0.5X auxiliary lens, an adapter with 1.0X lens and 1/2 "CCD camera and 13" monitor.

1. First locate your electronic magnification using the chart above :

Electronic Magnification = 41.3

2. Determine the optical magnification :

(Objective Mag. = 0.7X ~ 4.5X) x (Auxiliary Lens Mag.= 0.5X) x (adapter Mag.=1X)

Optical Magnification = 0.35X ~ 2.25X

3. Total on-screen magnification :

Total On-Screen Magnification = Electronic Magnification x Optical Magnification

= 41.3 x 0.35X ~ 2.25X

= Range: 14.46X ~ 92.93X

CALCULATING SPECIMEN SIZE ON YOUR TV MONITOR

The following formula can be utilized for determining the actual size of a specimen : Divide the length of the specimen as measured on the monitor by the total magnification of the monitor.

$$\text{Actual Specimen Size} = \frac{\text{Length of Specimen as Measured on the Monitor}}{\text{Total Magnification}}$$

Example : If we use the value of the total on screen magnification calculated at the lower end of the zoom range or 14.46 and if the length of the specimen as measured on the monitor is 150mm then the real size of the specimen would be: 150mm/14.46 or 10.37mm

ADAPTERS WITH BUILT-IN LENSES FOR SHORT "UNIMAC" SERIES



Cat. No.	DESCRIPTION
① MA155/10/03	"C" Mount adapter with 0.3X lens and reticle mount
② MA155/10/04	"C" Mount adapter with 0.45X lens and reticle mount
③ MA155/10/15	"C" Mount adapter with 1.0X lens and reticle mount
④ MA155/10/20	"C" Mount adapter with 0.7X lens and reticle mount
⑤ MA155/10/25	"C" Mount adapter with 2.5X lens and reticle mount

The Adapters with built-in lenses are used to adjust the field of view on your TV monitor without changing the working distance of your direct video lens. The optimal field of view is generally achieved when the Adapter magnification is closely matched to your camera format or chip size. For example an adapter with a 0.3X lens is best suited for use with a 1/3" camera and an adapter with a 0.45X lens is best suited for use with a 1/2" Chip camera. Selecting an adapter with the incorrect magnification for your camera format may result in "vignetting" (black corners). All of the "C" mount adapters have reticle mounts. The MA155/10/15 Adapter with a 1.0X magnification factor is used to image the reticle at the same magnification of the direct video lens in use.

DIGITAL CAMERA ADAPTERS



The MA151/40/50 digital camera adapter is designed to connect Short "UNIMAC" Series direct video zoom lenses directly to Nikon Cool Pixs models 950, 990 and 995 digital cameras.

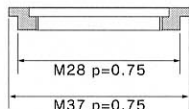

The MA151/37 digital camera coupler is used in conjunction with the MA151/40/50 digital camera adapter. This coupler allows you to convert the M28 x 0.75 thread of the MA151/40/50 to a M37 x 0.75 internal thread.

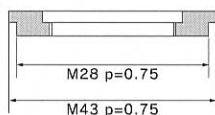

The MA151/43 digital camera coupler is used in conjunction with the MA151/40/50 digital camera adapter. This adapter allows you to convert the M28 x 0.75 thread of the MA151/30/50 to a M43 x 0.75 internal thread.

COLOR CCD CAMERAS



CK3900



CK3100

Common Features:

- TV Standard NTSC/PAL
- NTSC: 525 lines, 30 frames/second
PAL: 625 lines, 25 frames/second
- NTSC: 768(h)x 494(v)
- PAL: 752(h)x 582(v)
- 450 TV lines of horizontal resolution
- S/N ratio > 50 db
- Color 1/2" or 1/3" HADTM IT CCD sensor
- Composite VBS and Y/C output
- Serial Interface: RS232
- Auto iris and CCD iris for light regulation
- Sensitivity: 0.4 lux on sensor
- Manual shutter speed up to 1/10,000 sec.
- Lens Mount: C/CS
- 12V DC power

STANDS AND FOCUS BLOCKS

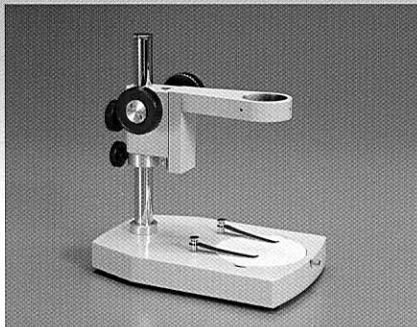

MS-51
Coarse focus block with pole type stand

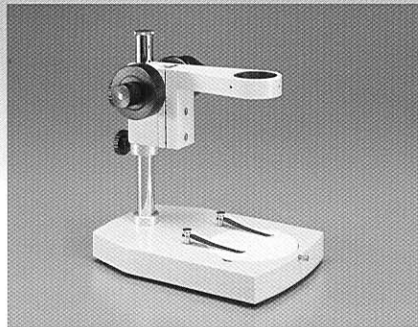

MS-53
Coarse and fine focus block with pole type stand

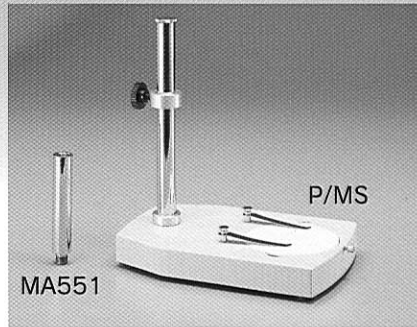

MA551

P/MS

P/MS
Pole type stand for MS-51/05 and MS-53/05 Focus block, reversible white and back stage plate, two stage clips (8.35" pillar)

MA551

100mm (4") pillar extension for P/MS stand

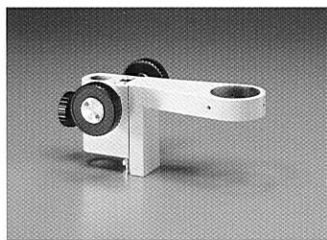

MS-51/05
Coarse focus block
(Fits 20mm mounting post)

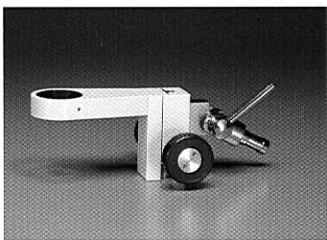

MS-52/05
Inclinaible coarse focus block
(With 5/8" mounting pin)



MS-53/05
Coarse and fine focus block
(Fits 20mm mounting post)

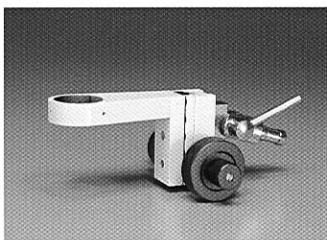

MS-54/05
Inclinaible coarse and fine focus block
(With 5/8" mounting pin)

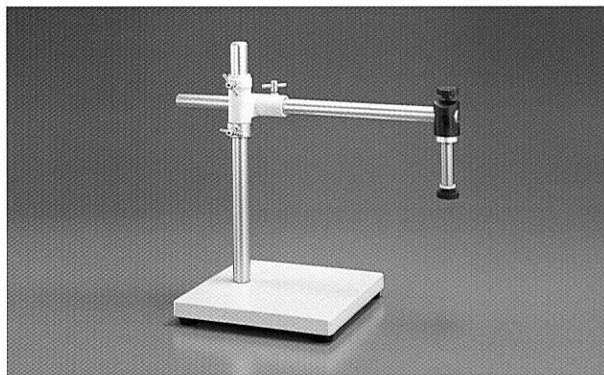

S-4100

Universal stand with mounting post for MS-51/05 and 53/05 Focus block, vertical Pole 400mm (15.74") long and horizontal pole 530mm (20.87") long

S-4200

The S-4200 is same as S-4100 but with 620mm (24.0") long vertical pole

DIMENSIONS OF MACROZOOM FOCUS BLOCKS

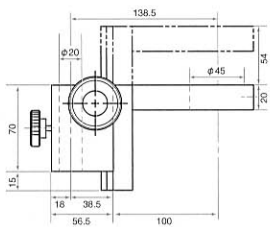

MS-51/05

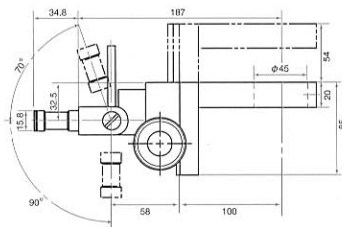

MS-52/05

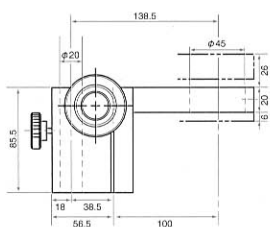

MS-53/05

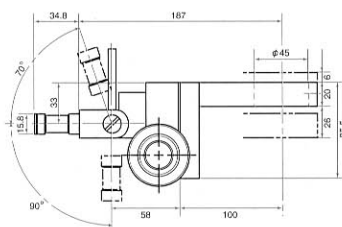

MS-54/05

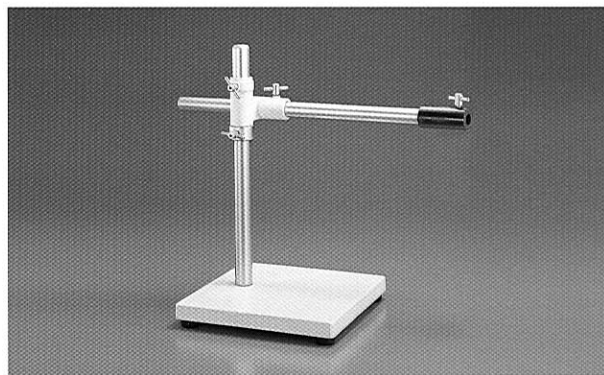

S-4300

Universal stand with adapter (552) for MS-52/05 and 54/05 Focus block, vertical Pole 400mm (15.74") long and horizontal pole 535mm (21.06") long

S-4400

The S-4400 is same as S-4300 but with 620mm (24.0") long vertical pole

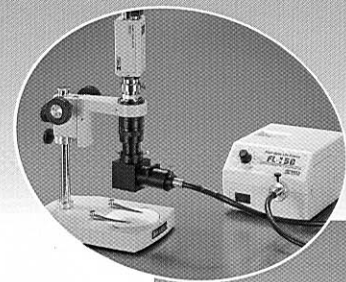

INCIDENT REFLECTOR FOR COAXIAL ILLUMINATION

Attachable to macrozoom lenses. For use with FL150/80 Single fiber light guide and FL150 light source.

Cat.No. : MS-21



Flexible 36" single arm fiber optic light guide for use with MS-21 incident reflector

Cat.No. : FL150/80

Light source: halogen lamp. 21V 150W, with variable light-intensity regulation.

Cat.No. : FL150/115 (115V)

FL155/200 (220/230V)

MS-21

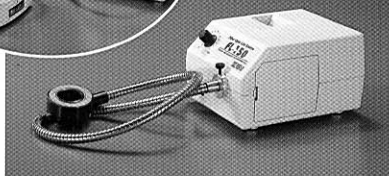

ANNULAR FIBER OPTIC ILLUMINATOR

150 Watt quartz halogen light source with 31mm I.D. annular light guide and adapter. Rheostat controlled intensity, UL Listed and CSA approved.

Cat.No. : FL155/115 (115V)

FL155/200 (220/230V)

Replacement Bulb: FL180/70 (21V 150W)

FL155

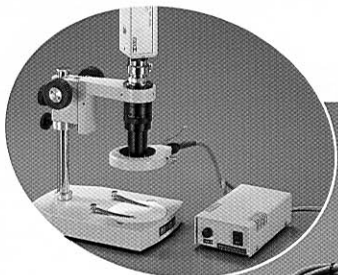

RING FLUORESCENT ILLUMINATOR

Provides 360° of cool white shadow-free illumination. Lightweight, compact and rugged. Light Output : 8W, Color temperature : 6,500°k, Lamp life : 1,500 hours. With MS-12 adapter,

Cat.No. : MA305/MS-12/115 (115V)

MA305/MS-12/200 (220/230V)

Replacement Bulb: MA305/05

MA305/MS-12

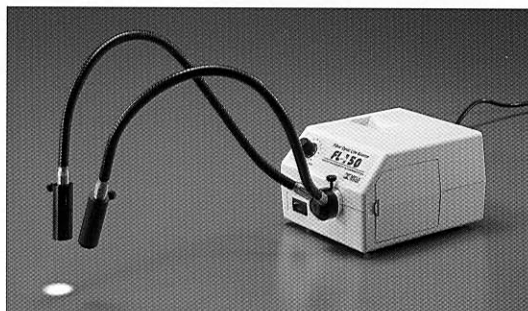

DUAL-ARM FIBER OPTIC ILLUMINATOR

150 Watt quartz halogen light source with self-supporting dual arm light guides and focus lenses. Rheostat controlled intensity. Color temperature 3200°k. UL listed and CSA approved

Cat.No. : FL151/115 (115V)

FL151/200 (220/230V)

FL151



Agent:

MEIJI TECHNO AMERICA

2186 Bering Drive
San Jose, CA., 95131, USA
Phone : 408-428-9654 Fax : 408-428-0472
Toll free : 800-832-0060



MEIJI TECHNO CO.,LTD.

322-1, Chikumazawa
Miyoshi-machi, Iruma-gun
Saitama 354-0043, Japan
Phone : (0)49-259-0111 Fax : (0)49-259-0113

<http://www.meijitechno.com>